

User Manual

Paperless Recorder VR18

BrainChild

Brainchild Electronic Co., Ltd.

UMVR181P

15th Edition, 01/2007

Contents	Page
Safety -----	4
Safety Symbols -----	4
Safety Notes and Precautions -----	4
Static Electricity -----	5
1. General Description -----	6
1.1 Unique Features of Recorder -----	6
1.2 Expandable Input and Output cards -----	6
1.3 Communication -----	6
1.4 Storage Media CF card -----	7
1.5 Data Security -----	7
1.6 Infrared Detector -----	7
1.7 Ordering Codes and Accessories -----	8
1.8 Specifications -----	11
2. Installation and wiring -----	14
2.1 Unpacking -----	14
2.2 Installation -----	14
2.3 Setup Input, Output & 24VDC power supply cards -----	21
2.4 Wiring of the cards -----	23
2.5 RS-232, RS-422, RS-485 wiring -----	26
2.6 Installation of Compact Flash CF Card -----	28
3. Basic Operation -----	29
3.1 Page -----	29
3.2 Mode -----	30
3.3 History -----	31
3.4 Event -----	32
3.5 Status -----	33
3.6 Exit -----	33
3.7 Dump -----	34
3.8 Clear -----	34
3.9 Operate -----	34
3.10 Shutdown -----	34
3.11 Logout -----	34
3.12 Small Icons -----	35
4. Configuration -----	36
4.1 Channel (Analog input, Digital input, Analog output, Math input) -----	37
4.2 Display -----	43
4.3 Tools (Timer, Counter & Totalizer) -----	45
4.4 Instrument -----	50
4.5 Clock -----	53
4.6 Security & FDA 21 CFR part 11 compliance -----	54
4.7 Demo -----	55

4.8	System Info -----	55
4.9	A Configuration Example -----	56
5.	PC software and Communication configuration -----	57
5.1	Observer I & Observer II PC software guide -----	57
5.2	Ethernet Configuration -----	61
5.3	RS 232, RS485, RS422 Configuration -----	65
5.4	CF card Configuration -----	70
5.5	Configuration in Real-Time Viewer -----	73
5.6	DDE dynamic data exchange -----	77
6.	Application examples -----	83
7.	Trouble shooting -----	86
8.	FAQs frequently asked questions -----	89

Safety

This recorder is compliant with the requirements of EN61010-1, UL 61010C-1 & CSA C22.2 No. 24-93. The protection provided by the recorder may be impaired if it is used in a manner inconsistent with its intended purpose, or in an environment that exceeds the specifications of the recorder. Brainchild Electronic Co., Ltd. is not liable for customer's failure to comply with these requirements.

Safety Symbols

The following symbols may be seen on the user manual or recorder labeling.



Caution



Protective Earth



DC Supply

Safety Notes and Precautions

1. The protective earth terminal should be connected first before any other connection is made. To avoid making the recorder dangerous under fault conditions, any interruption of the protective Earth conductor inside or outside the recorder is prohibited. Even in the case of a portable unit, the protective earth terminal must remain connected if the recorder is connected to any hazardous voltage.
2. Keep signal and supply voltage wiring separated from one another. If this is impractical, use shielded cables for signal wiring. Double insulation should be used for signal wiring when the recorder is being used with hazardous voltage.
3. Do not use the recorder where there is high vibration, or high magnetic field, this could cause damage or error of measurement.
4. All maintenance or repairs should be carried out with power disconnected, to avoid personal injury, or damage to the unit.
5. In areas with conductive pollution, adequate ventilation, filtering and sealing need to be installed.

6. When cleaning the recorder, handle carefully and use soft dry cloth. Avoid the use of abrasives or any sharp and hard objects, which would damage the display.
7. Do not operate the recorder if any part has been removed or disassembled. Consult your nearest dealer at once.

Static Electricity

Appropriate precautions must be taken when handling the recorder. The circuit board, components are susceptible to damage caused by electrostatic discharge. Take static electricity precautions whilst handling and inserting Compact Flash Card into the recorder.

To replace the power-line fuse

The power-line fuse is located within the fuse-holder on the power board. For 90-250 VAC line voltages, the user must use a 2.5A/250VAC time-lag fuse, and for both 11-18 VDC and 18-36 VDC line voltages, a 5.0A/250VAC time-lag fuse must be used.

1. General Description

1.1 Unique features of recorder

The VR18 is a well-designed paperless recorder with many outstanding features including:

- 6.4" TFT Color LCD with VGA Display in 640x480 pixels.
- 18 isolated Analog Inputs
- Plug & play I/O cards for easy expansion
- Simple and friendly operation
- Infrared detector to prolong lifetime of LCD
- Solid storage media CF card in high capacity
- 174 mm short depth
- Ethernet as standard and optional RS-232/422/485 communication
- High accuracy 18-bit A-D Analog Input
- 15-bit D-A Analog Output.
- 200 milli second sample rate.
- Bench top with convenient portable handle, easy converted into panel mount

1.2 Expandable Input and Output Cards

The recorder is equipped with six-rear expansion slots, which work flexibly with the following plug & play I/O cards.

Analog Input cards (part number AI181, AI182, AI183) : These three cards are used for 1, 2, & 3-channel analog input. Each input is isolated from each other to avoid noise and to ensure stable measurement. *Analog input is configured by DIP switches and jumpers on the card before plugging into rear expansion slot. Refer 2.3 Setting Input and Output Cards.*

Digital Output card (DO181): Each card includes 6 alarm relays. Contacts are rated 5 Amp/240 VAC

Digital Input card (DI181): Each card includes 6 channels. Logic Low: -5V minimum, 0.8V maximum, Logic High: -2V minimum, 5V maximum

Analog Output cards (AO183I, AO183V): Each card includes 3 channels. AO183I is used for 4-20mA, 0-20mA current output, and AO183V is used for 0-5V, 1-5V, 0-10V voltage output.

1.3 Communication

The standard communication interface is Ethernet with protocol IEEE 802.3 - 10 Base T. Other options are RS-232 / RS-422 / RS-485.

1.4 Storage Media CF Card

The Solid Compact Flash Memory Card (CF card) 128 MB capacity is a free standard storage media used for this instrument. Its compact size, anti-dust and anti-vibration features increase its reliability. To read measured data on CF Card, add a CF reader on USB port of PC. Higher capacity 512 MB and 1GB CF Cards are upon request. Alternatively the user may purchase locally. To ensure compatibility, we recommended only one brand **SanDisk**. If the recorder is used with **6-channel inputs**, an easy chart to show the maximum days CF can store the data.

CF card	128MB	512MB	1GB
Log speed			
1 second	120 days	480 days	960 days
10 seconds	1200 days	4800 days	9600 days
120 seconds	14400 days	57600 days	115200 days

Each record of data uses 2 bytes of CF card memory.. If the Log Speed (the recording speed of measured data) is set to the fastest speed at 1 second per data, then for a single channel, 128 MB CF card will last approximately 740 days [= 128 MB / (2 bytes x 24 hours x 60 minutes x 60 seconds)].

The following formula is to calculate how many days the CF card could do saving before it is full.

The ? days = The capacity of CF Card / (2 bytes / the Log Speed x the working hours per day x 3600 seconds)

To avoid losing recorded data while storing on PC, it is necessary to insert CF card back again into the recorder soon after loading recorded data onto PC.

1.5 Data Security

The recorded data is stored in the manufacturer's special binary format. It is not possible to manipulate or modify the recorded data. This feature fully guarantees the security of the data.

1.6 Infrared Detector (IR Detector)

The use of Passive Infrared technology on the recorder is an innovative idea to prolong the lifetime of the LCD display. The detector senses the movement of body heat from a distance of approximately 2 meters. This feature works together with the Screensaver. For example, if the IR Sensor is turned on and Screensaver set to 10 Min, then the display will turn off 10 minutes after the user walks away from the recorder. The Passive Infra Red detects when the user returns to the recorder and the display turns on straight away, no need to press any key on the recorder. If the user does not prefer using this function, it can be disabled.

1.7 Ordering codes and accessories

Ordering codes

VR18 – – –
 1 2 3 4 – 5 6 7 – 8 9 10

1 Power

- 4: 90-250 VAC, 47-63 Hz
- 5: 20-28 VAC, 47-63 Hz
- 6: 11-18 VDC
- 7: 18-36 VDC
- 8: 36-72 VDC
- 9: Special order

2 Analog Input Card

- 0: none
- 1: 1 channel with AI181
- 2: 2 channels with AI182
- 3: 3 channels with AI183
- 4: 4 channels with AI181 & AI183
- 5: 5 channels with AI182 & AI183
- 6: 6 channels with AI183
- A: 9 channels with AI183
- B: 12 channels with AI183
- C: 15 channels with AI183
- D: 18 channels with AI183
- G: 3 channels with AI183V
- H: 6 channels with AI183V
- J: 9 channels with AI183V
- K: 12 channels with AI183V
- L: 15 channels with AI183V
- M: 18 channels with AI183V

*See AI181/2/3(V) in Accessories below.

3 Digital Input Card

- 0: none
- 1: 6 channels
- 2: 12 channels
- 3: 18 channels
- 4: 24 channels
- 5: 30 channels
- 6: 36 channels

4 Digital Output Card

- 0: none
- 1: 6 relays
- 2: 12 relays
- 3: 18 relays
- 4: 24 relays

5 Communication

- 0: standard Ethernet interface
- 1: RS-232/422/485 (three in one) + Ethernet interface
- 9: Special order

6 PC software

- 1: Free basic software Observer I for non-communication application
- 2: Extensive software Observer II for communication of RS-232/422/485 or Ethernet

7 Firmware

- 0: Basic function
- 1: with Mathematics, Counter & Totalizer & FDA 21 CFR part 11 compliance

8 Storage Media

- 1: 128MB Compact Flash card
- 5: 512 MB CF card
- 6: 1 GB CF card
- X: other options

删除: 4: 256 MB CF card

9 Case/Mounting

- 1: standard panel mounting, grey case
- 2: Bench top / portable style with handle, USA power cable, grey case
- 3: Bench top with handle, European power cable, grey case
- 4: standard panel mounting, black case
- 5: Bench top / portable style with handle, USA power cable, black case
- 6: Bench top with handle, European power cable, black case

10 Special Option:

- 0: none
- 1: 24VDC auxiliary power supply (for transmitter, 6 channels)
- 2: 3-channel current output
- 3: 6-channel current output
- 4: 9-channel current output
- D: 3-channel voltage output
- E: 6-channel voltage output
- F: 9-channel voltage output
- 5: panel mounting with rear power plug
- 6: panel mounting with front power switch
- 7: 7=1+5
- 8: 8=1+6
- 9: 9=1+5+6
- X: other options

Accessories:

Part no.	Descriptions
AI181, AI182, AI183	1, 2, 3-channel analog input card (TC, RTD, + mA, + V, + mV)
AI183V	3-channel voltage input card (\pm mA, \pm V, \pm mV only)
DI181	6-channel digital input card
DO181	6-channel relay output card (AC/DC)
AP181	24 VDC auxiliary power supply card for 6 transmitters
CM181	RS-232/422/485 + Ethernet communication module
CM182	Standard Ethernet communication module
PM181	90-250 VAC, 47-63 Hz power supply
PM182	11-18 VDC power supply module
PM183	18-36 VDC power supply module
PM184A	90-250 VAC, 47-63 Hz power supply with power plug and USA power cable
PM184E	90-250 VAC, 47-63 Hz power supply with power plug and European power cable
PM185	36-72 VDC 47-63 Hz power supply
PM186	20-28 VAC power supply,
MK181	panel mount assembly kit (grey color)
MK181B	panel mount assembly kit (black color)
MK183	bench top / portable handle assembly kit (grey color)
MK183B	bench top / portable handle assembly kit (black color)
CF128	128MB compact flash card
CF512	512MB compact flash card
CF102	1 GB compact flash card
AS181	Basic PC software Observer I
AS182	Extensive PC software Observer II
AO183I	3-channel current output card
AO183V	3-channel voltage output card
BT181	Boot ROM without Math, Counter & Totalizer
BT182	Boot ROM with Math, Counter & Totalizer & FDA 21 CFR part 11
SC181	The Slot cover of an empty slot
SNA10A	RS-485 to RS-232 converter
UMVR181	User Manual

删除: PM184 90-250 VAC, 47-63 Hz power supply with power plug

删除: with USA cable

删除: with USA cable

删除: MK184 bench top / portable handle assembly kit (grey color) with Europe cable
MK184B bench top / portable handle assembly kit (black color) with Europe cable

Notes:

- ◆ The rear Slots of the recorder will only accept up to 6 optional cards of input, output or 24 VDC power supply in any combination. For example, 12-channel analog input needs 4 pieces of 3-channel analog input card AI183. Now it is left 2 empty Slots for other cards.
- ◆ The basic PC software **Observer I** is supplied free together with recorder. There is an additional charge for the extensive PC software **Observer II** supplied with communication of RS-232/422/485 or Ethernet.

The Ordering Code of standard model without any option is VR18-4X00-010-110

删除:

1.8 Specifications

Power

90-250VAC, 47-63Hz, 60VA, 30W maximum
11-18VDC or 18-36 VDC, 60VA, 30W maximum

Display

6.4" TFT LCD, 640X480 pixel resolution, 256 colors

Memory

8MB storage memory on board
Storage media: 128, 512 MB, 1 GB CF (Compact Flash) cards

Analog Input Cards (AI181, AI182, AI183)

Channels: AI181 ~ 1 channel, AI182 ~ 2 channels, AI183 ~ 3 channels

Resolution: 18 bits

Sampling Rate: 5 times/ second

Maximum Rating: -2 VDC minimum, 12 VDC maximum (1 minute for mA input)

Temperature Effect: $\pm 1.5 \mu\text{V}/^\circ\text{C}$ for all inputs except mA
 $\pm 3.0 \mu\text{V}/^\circ\text{C}$ for mA input

Sensor Lead Resistance Effect:

T/C: $0.2 \mu\text{V}/\text{ohm}$ 3-wire RTD: $2.6^\circ\text{C}/\text{ohm}$ of resistance difference of two leads

2-wire RTD: $2.6^\circ\text{C}/\text{ohm}$ of resistance sum of two leads

Burn-out Current: 200nA

Common Mode Rejection Ratio (CMRR): 120dB

Normal Mode Rejection Ratio (NMRR): 55dB

Isolation Breakdown Voltage between channels: 430VAC min.

Sensor Break Detection: Sensor opened for TC, RTD and mV inputs, below 1 mA for 4-20mA input, below 0.25V for 1-5V inputs, unavailable for other inputs

Sensor Break Responding Time: Within 10 seconds for TC, RTD and mV inputs, 0.1 second for 4-20 mA and 1-5V inputs

Characteristics:

Type	Range	Accuracy at 25 °C	Input Impedance
J	-120 ~ 1000 °C (-184 ~ 1832 °F)	$\pm 1^\circ\text{C}$	2.2M Ω
K	-200 ~ 1370 °C (-328 ~ 2498 °F)	$\pm 1^\circ\text{C}^*$	2.2M Ω
T	-250 ~ 400°C (-418 ~ 752°F)	$\pm 1^\circ\text{C}$	2.2M Ω
E	-100 ~ 900 °C (-148 ~ 1652 °F)	$\pm 1^\circ\text{C}$	2.2M Ω
B	0 ~ 1820 °C (32 ~ 3308 °F)	$\pm 2^\circ\text{C}$ (200 ~ 1820 °C)	2.2M Ω
R	0 ~ 1768 °C (32 ~ 3214 °F)	$\pm 2^\circ\text{C}$	2.2M Ω
S	0 ~ 1768 °C (32 ~ 3214 °F)	$\pm 2^\circ\text{C}$	2.2M Ω
N	-250 ~ 1300 °C (-418 ~ 2372 °F)	$\pm 1^\circ\text{C}$	2.2M Ω
L	-200 ~ 900 °C	$\pm 1^\circ\text{C}$	2.2M Ω

	(-328 ~ 1652 °F)		
PT100 (DIN)	-210 ~ 700 °C (-346 ~ 1292 °F)	±0.4 °C	1.3KΩ
PT100 (JIS)	-200 ~ 600 °C (-328 ~ 1112 °F)	±0.4 °C	1.3KΩ
mV	-8 ~ 70mV	±0.05%	2.2MΩ
mA	-3 ~ 27mA	±0.05%	70.5Ω
0~1V	-0.12 ~ 1.15V	±0.05%	332KΩ
0~5V	-1.3 ~ 11.5V	±0.05%	332KΩ
1~5V	-1.3 ~ 11.5V	±0.05%	332KΩ
0~10V	-1.3 ~ 11.5V	±0.05%	332KΩ

Analog Input Cards (AI183V)

Characteristics:

Type	Range	Accuracy at 25 °C	Input Impedance
-60~60mV	-62~62mV	±0.1%	2.2 MΩ
-2~2V	-2.2~2.2V	±0.3%	332KΩ
-20~20 V	-22~22 V	±0.1%	332KΩ
-20~20 mA	-22~22 mA	±0.1%	70.5Ω

Digital Input Card (DI181)

Channels: 6 per card
 Logic Low: -5V minimum, 0.8V maximum
 Logic High: 2V minimum, 5V maximum
 External pull-down Resistance: 1KΩ maximum
 External pull-up Resistance: 1.5MΩ minimum

Digital Output Card (DO181)

Channels: 6 per card
 Contact Form: N.O. (form A)
 Relay Rating: 5A/240 VAC, life cycles 200,000 for resistive load

Analog Output Card (AO183I, AO183V)

Channels: 3 per card
 Output signal: AO183I: 4-20mA, 0-20mA, AO183V: 0-5V, 1-5V, 0-10V
 Resolution: 15 bits
 Accuracy: ±0.05% of Span ±0.0025% /°C
 Load Resistance: 0-500 ohms (current), 10K ohms minimum (voltage)
 Output Regulation: 0.01% for full load change
 Output Setting Time: 0.1 second (stable to 99.9%)
 Isolation Breakdown Voltage: 1000VAC min.
 Integral Linearity Error: ±0.005% of Span
 Temperature Effect: ±0.0025% of Span /°C

24VDC Auxiliary Power Supply Card (AP181)

Channels: to be used for 6 transmitters
 Output Rating: 24 ± 1 VDC, 180mA in maximum, 30mA / each channel

COMM Module (CM181)

Interface: RS-232 (1 unit), RS-485 or RS-422 (up to 247 units)
Protocol: Modbus Protocol RTU mode
Address: 1-247
Baud Rate: 0.3~38.4 Kbits/sec.
Measured data Bits: 7 or 8 bits
Parity Bit: None, Even or Odd
Stop Bit: 1 or 2 bits

Standard Ethernet Communication

Protocol: Modbus TCP/IP, 10 Base T
Ports: AUI (Attachment Unit Interface) and RJ-45, Auto- detect capability

Infrared Detector

Distance: Detect moving human body in distance around 2 meters
Time delayed: 10, 20, 30, 40, 50 or 60 minutes to be defined

Real time clock accuracy vs. temperature inside of housing

Temperature inside housing	typical error per month
10 ~ 40 °C	18 seconds
0 °C or 50 °C	52 seconds
-10°C or 60 °C	107 seconds

Environmental & Physical

Operating Temperature: 5 ~ 50 °C
Storage Temperature: -25 ~ 60 °C
Humidity: 20 to 80% RH (non-condensing), maximum relative humidity 80% for temperature up to 31°C decreasing linearly to 50% relative humidity at 40°C
Altitude: 2000 M maximum
Insulation Resistance: 20 M ohms min. (at 500 VDC)
Dielectric Strength: 1350 VAC, 50/60 Hz for 1 minute
Vibration Resistance: 10-55 Hz, 10m/ s² for 2 hours
Shock Resistance: 30m/ s² (3g) for operation, 100g for transportation
Operation Position: no inclined restriction
Dimensions: Panel Mount style: 166(W) x 144(H) x 174mm(D)
Bench Top style: 166 (W) x 192 (H) x 194mm (D)
Standard Panel Cutout: DIN size in 138 x 138mm

Approval Standards

Safety: UL61010C-1, CSA C22.2 No. 24-93
CE: EN61010-1 (IEC1010-1) over voltage category II, Pollution degree 2

Protective Class: IP 30 front panel for indoor use,
IP 20 housing and terminals

EMC:

Emission: EN61326 (EN55022 class A, EN61000-3-2, EN61000-3-3)

Immunity: EN61326 (EN61000-4-2, EN61000-4-3, EN61000-4-4,
EN61000-4-5, EN61000-4-6, EN61000-4-8, EN61000-4-11)

2. Installation and wiring

2.1 Unpacking

If any damage is found while unpacking, the user should contact the local representative at once. It is suggested that the special packaging is retained for possible future requirement.

2.2 Installation

⚠ Remove stains from this equipment using a soft, dry cloth. Don't use harsh chemicals, volatile solvent such as thinner or strong detergents to clean the equipment in order to avoid deformation.

The recorder is designed for indoor use and not in any hazardous area. It should be kept away from shock, vibration, and electromagnetic fields such as variable frequency drives, motors and transformers.

It is intended to operate under the following environment:

Pollution Degree Level II	IEC1010-1(EN61010-1)
Temperature	5 ~ 50 °C
Humidity	20 ~ 80 % RH (non-condensing)
Power	90 ~ 250 VAC, 50/60 Hz
	11-18 VDC or 18 - 36 VDC

Panel mounting style

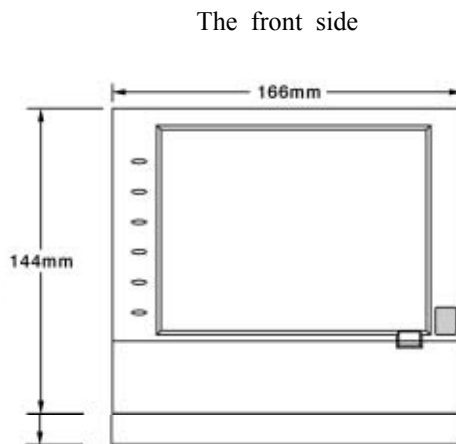

Figure 2 - 1

The right side

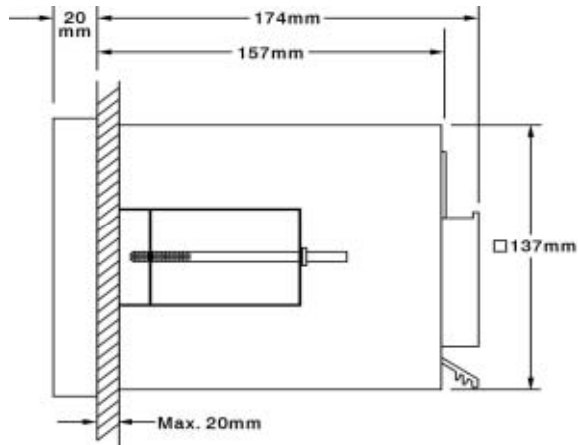

Figure 2 - 2

Panel Cutout (standard DIN size 138 mm x 138 mm)

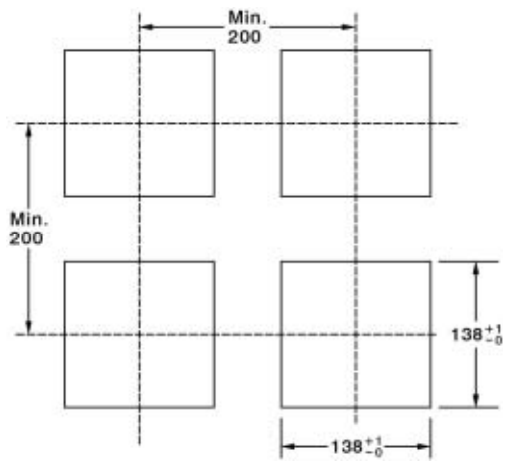

Figure 2 - 3

Note:

- ◆ Do not over tighten mounting clamp screws that could result in distortion of the case.
- ◆ There is no mounting angle restriction.

Bench top / Portable style

If the recorder is used for Bench Top or portable purpose, then the assembly Kit MK184 (two ears, one handle, two feet included) is required. Assemble as follows,

Firstly, put the right ear FV-R on the right hand side of metal case, and slide it into the case by pushing in direction as shown in **Figures 2-4 through Figure 2-8**. Ensure that the ear is firmly plugged into case. Do the same with the left ear FV-L.

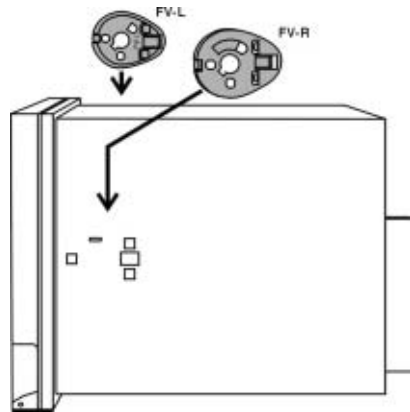

Figure 2 - 4

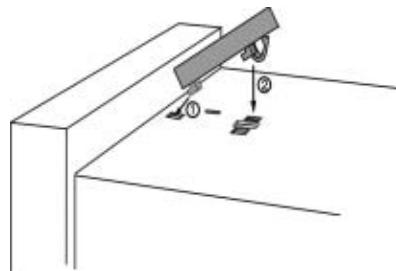

Figure 2 - 5

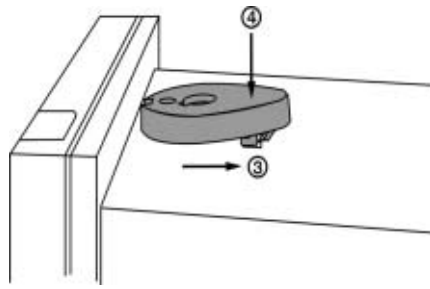

Figure 2 - 6

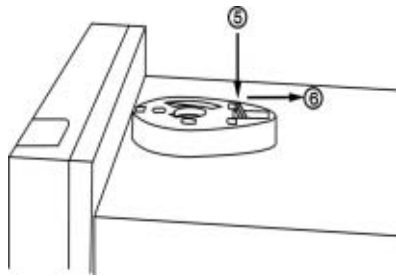

Figure 2 - 7

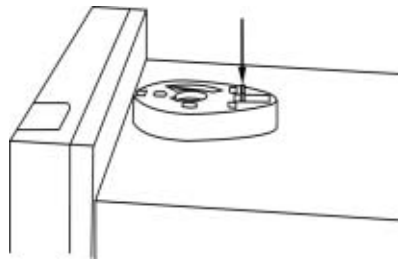

Figure 2 - 8

Holding the handle so that the instruction side can be seen, pull the handle outward by both hands and put it in vertical position on the top of case. Then, slide the handle into both ears as **Figure 2-9**. Rotate the handle downward as **Figure 2-10 & 2-11**. Lastly, slide both feet beneath the case and straighten up the stoppers as **Figure 2-12** **Figure 2-14**. The bench top recorder is now mechanically ready.

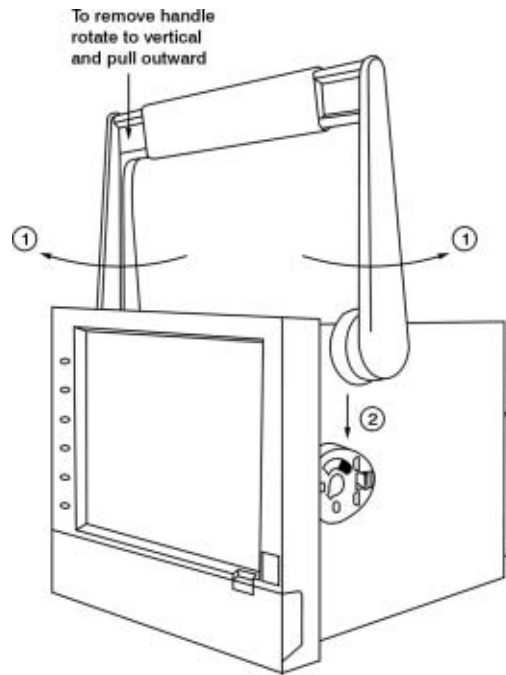

Figure 2 - 9

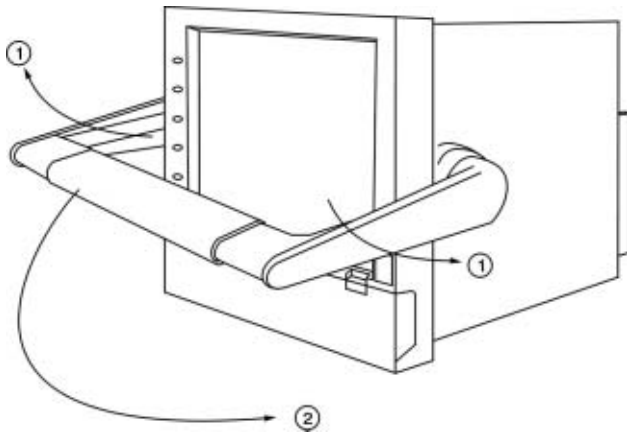

Figure 2 - 10

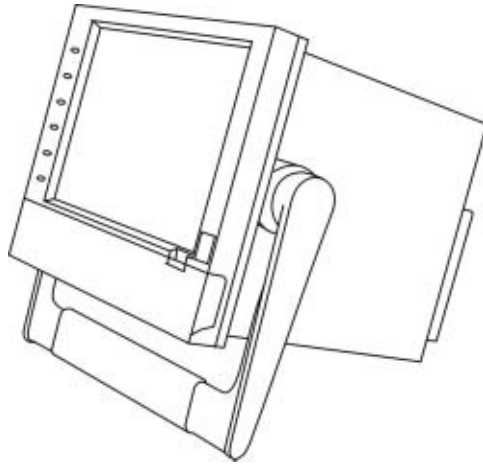

Figure 2 - 11

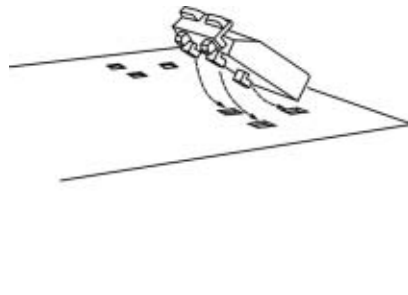

Figure 2 – 12

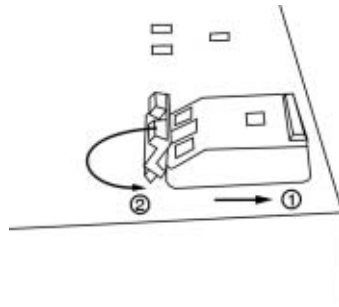

Figure 2 – 13

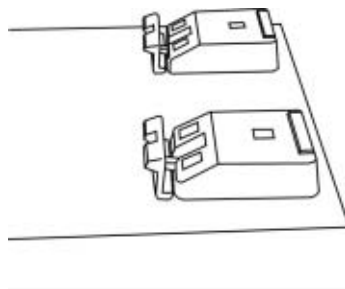

Figure 2 – 14

Note:

- ◆ To change the bench top into panel mount. Disassemble kit MK184 (one handle, two feet, and two ears) in reverse of above, then fit the mounting clamps.

2.3 Setup input, output & 24VDC power supply cards

Analog input cards (part numbers AI181, AI182, AI183)

AI181, AI182, AI183 are analog input cards in 1, 2, 3 channels respectively. Each card includes universal input of TC (J, K, T, E, B, R, S, N, L), PT100, mV, mA, V. To select a specific input, first set jumpers and switches according to the sticker information on the card as **Figure 2-15**, and plug it into the rear slot then power on. The recorder will automatically detect the card and display the specific input type, then show its source of a specific slot in Configuration Mode. All inputs were initially set for 4-20mA from the factory.

JUMPER AND SWITCH SETTING			V1.9								OTA1182C	
FUNCTION	MINI-JUMPER			DIP SW SETTING								
	J1	J2	J3	1	2	3	4	5	6	7	8	
UNIT	°C	T/C or RTD	—									
	°F	T/C or RTD	—	■								
	mV	0 ~ 60mV	—								■	
		0~1000mV	—			■						■
	V	0 ~ 5V	—					■		■		
		1 ~ 5V	—					■		■		
		0 ~ 10V	—					■				
	mA	0 ~ 20mA		—		■	■					■
4 ~ 20mA			—			■	■				■	
THERMOCOUPLE	J				■							
	K					■						
	T				■	■						
	E						■					
	B				■	■						
	R					■	■					
	S				■	■	■					
	N									■		
	L				■					■		
	TC1					■	■					
RTD	PT100							■	■			
	JPT100				■			■	■			
	RTD1							■	■			

3-wire RTD	2-wire RTD	0~60mV, T/C	0~1000mV, V, mA

Figure 2 – 15

Analog input card (part number AI183V)

AI183V are analog input cards in 1, 2, 3 channels respectively. Each card includes linear input of $\pm 60\text{mV}$, $\pm 20\text{mA}$, $\pm 2\text{V}$, and $\pm 20\text{V}$ only. To select a specific input, first set jumpers and switches according to the sticker information on the card as **Figure 2–16**, and plug it into the rear slot then power on. The recorder will automatically detect the card and display the specific input type, then show its source of a specific slot in Configuration Mode. All inputs were initially set for $-20\text{mA}\sim 20\text{mA}$ from the factory.

JUMPER AND SWITCH SETTING for AI183V											
FUNCTION	MIN-JUMPER			DIP SW SETTING							
	J1	J2	J3	1	2	3	4	5	6	7	8
-60 ~ 60 mV		■		■	■	■			■		
-2 ~ 2 V	■								■	■	
-20 ~ 20 V		■		■					■	■	
-20 ~ 20 mA			■		■	■	■				

-60~60mV	-2~-2V, -20~20V, -20~20mA

Figure 2 – 16

Digital Output card (DO181) / 6 relay alarm card

The digital output card includes 6 relays rated 5 Amp/240 VAC. Plug the card into rear slot and power on. The recorder will automatically detect the card and then display the output type and its source of a specific slot in **System Info** mode whilst doing the configuration. To set up the digital output card, please refer to **Event, Job** of **4.1 Channel**.

Digital Input card (DI181)

This card includes 6 channels of event 1, 2, 3, 4, 5 & 6. As above, plug the card into rear slot and power on. The recorder will automatically detect it, and then display the input type and its source of a specific slot in **System Info** mode whilst doing the configuration.

Analog output cards (AO183I, AO183V)

These two cards are 3-channel current output card AO183I, and 3-channel voltage output card AO183V. They are used to retransmit process value to another device.

24 VDC auxiliary power supply card (AP181)

This card can supply the power to 6 transmitters. The output rating is $24 \pm 1\text{ VDC}$, 180 mA in maximum, 30mA / each transmitter.

2.4 Wiring of the cards

Wiring Precautions

1. Care must be taken to ensure that maximum voltage rating specified on the label is not exceeded.
2. For the panel-mount version, it is recommended that near the equipment an external fuse and an external switch rated at 2A/250 VAC should be equipped.
3. Beware not to over tighten the terminals screws. The torque should not exceed 0.7 N-m (6.3 Lb-in or 7.1 Kg F-cm).
4. Except the thermocouple wirings, all wirings should be stranded copper conductor with maximum gauge 18 AWG.
5. Connect a grounding conductor with 1.6mm diameter minimum to provide protective grounding prior to turning on the equipment.

Rear terminals

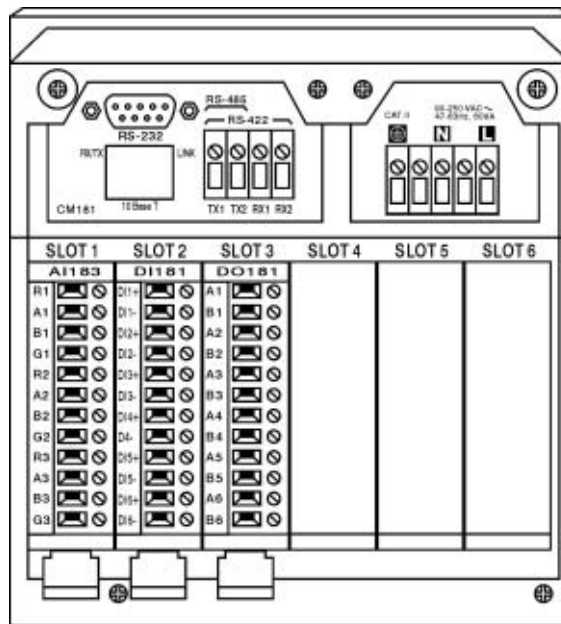

Figure 2 –17

Note:

- ▲ The six rear Slots can be inserted only by six cards in maximum. It can be either input card, output card or 24 VDC auxiliary power supply card.

Analog input cards (AI181, AI182, AI183)

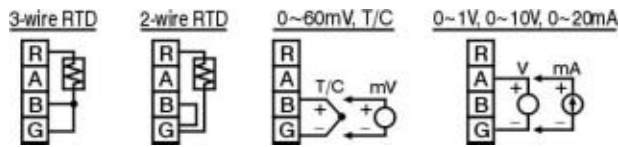

Figure 2 – 18

Analog input cards (AI183V)

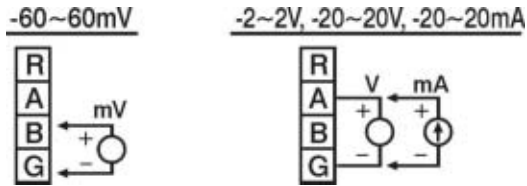

Figure 2 – 19

Digital output card (DO181)

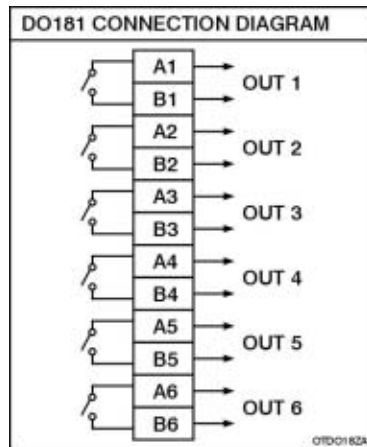

Figure 2 – 20

Digital input card (DI181)

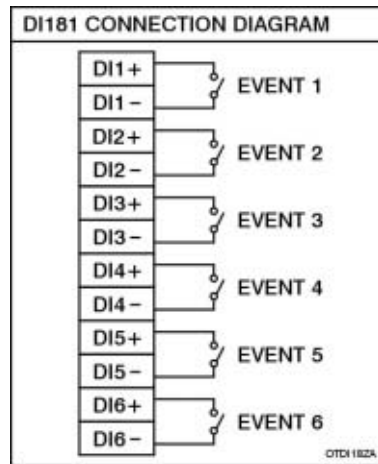

Figure 2 – 21

Analog output card (AO183I & AO183V)

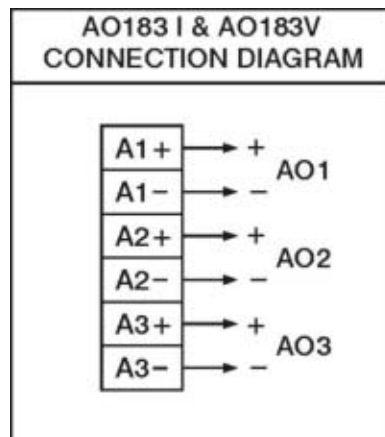

Figure 2 – 22

24 VDC auxiliary power supply card (AP181)

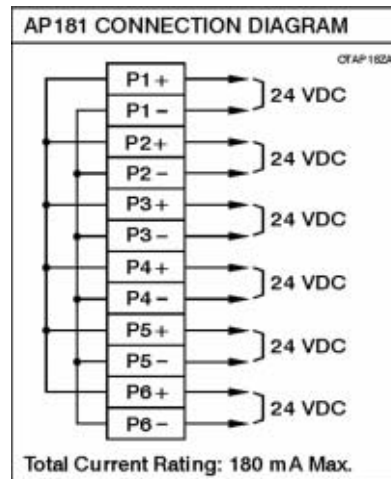

Figure 2 – 23

2.5 RS-232, RS-422, RS-485 wiring

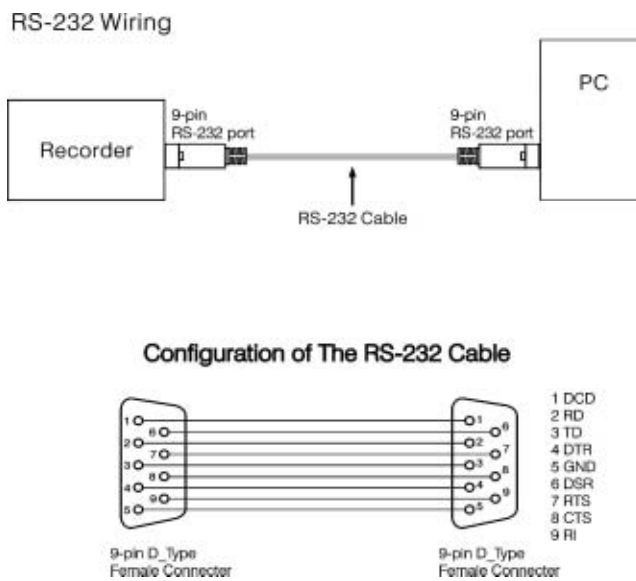

Figure 2 – 24

RS-422 Wiring

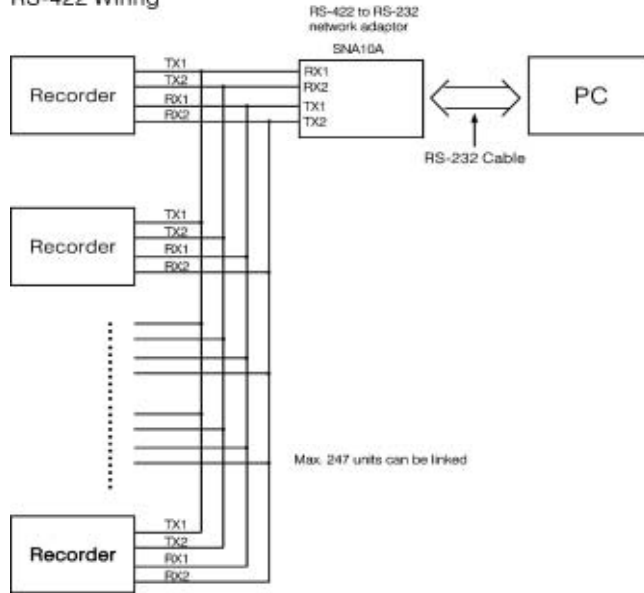

Figure 2 – 25

RS-485 Wiring

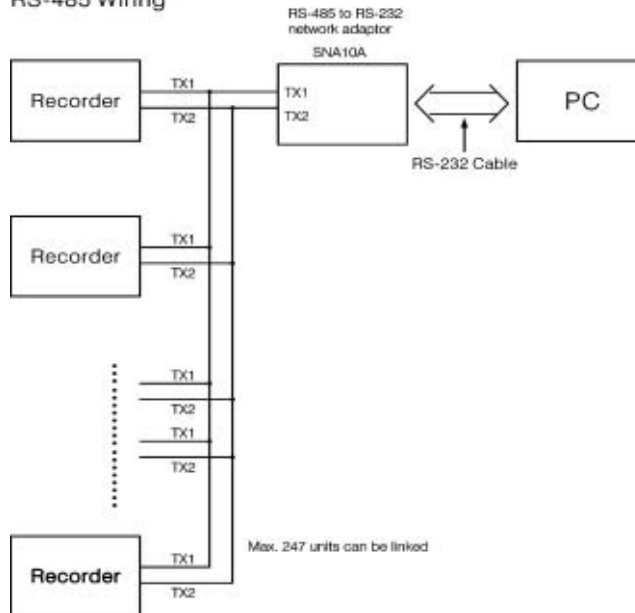

Figure 2 – 26

2.6 Installation of Compact Flash CF card

A 128MB Compact Flash Card is installed in each VR18. If a bigger capacity Compact Flash card is required, and the user decides to buy it locally, please check the brand name of CF card first. To be fully compatible, only one brand **SanDisk** is recommended.

Installation: First insert Compact Flash card to the end, then turn the stopper to the right.

Pulling out: First turn the stopper to the straight direction, then pull out the CF card.

Note:

- ◆ To read measured data and events on CF card, it is necessary to install software Observer I or II on PC first. Then, connect a CF reader to USB port of PC. Finally, insert CF card into the reader.
- ◆ The power should be turned off while inserting input and output cards. It is not recommended to insert input or output cards while the unit is switched on.

3. Basic Operation

After installation and wiring, power on the recorder, six soft keys Page, Mode, History, Event, Status and Exit will appear on the left hand side of LCD display. Opening the plastic cover at the front of the recorder, the user may find another five soft keys Dump, Clear, Operate, Config and Shutdown. These eleven soft keys are used for operation. On the top right side, small icons of buzzer, evnt, mem, CF and Date/Time display.

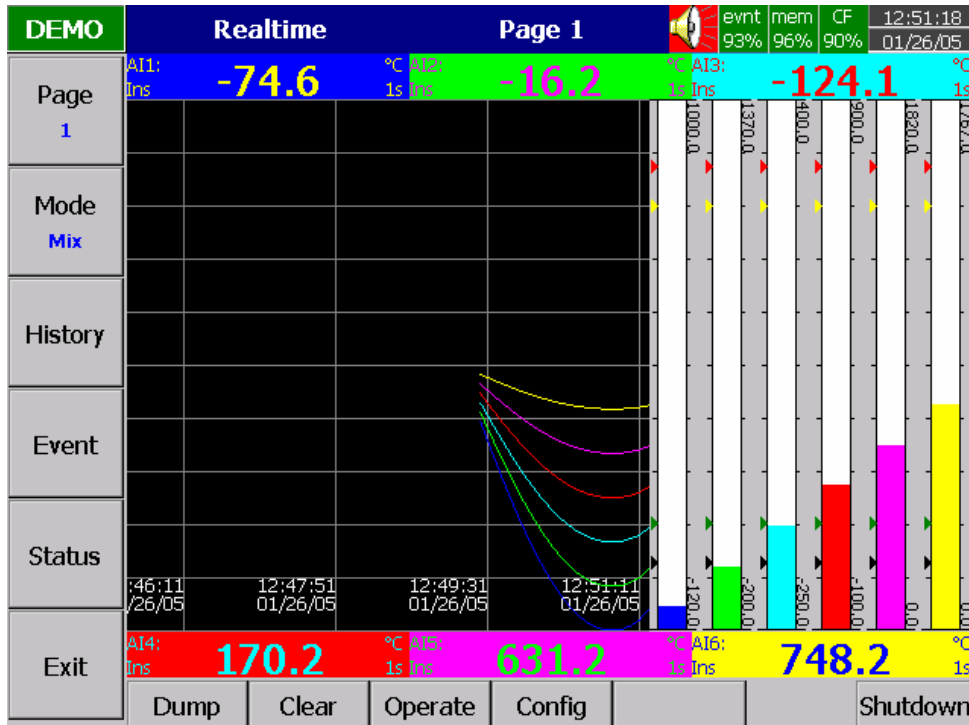

Figure 3 – 1

Soft keys :

3.1 Page

Page means the display. The recorder can have a maximum of 6 Pages and each Page can display a maximum of 6 channels. A channel can display either measured data or computed measured data. If channels cover more than one page, press the **Page** key, to move forward from Page 1 to Page 2...

Keep pressing **Page** key, you will get **Page All** to display all enabled channels.

DEMO	Realtime			All			evnt	mem	CF	12:58:58
Page All	AI1 517.1 °C	AI2 675.1 °C	AI3 104.8 °C	AI4 434.4 °C	AI5 951.8 °C	AI6 903.8 °C	87%	96%	90%	01/26/05
	AI7 -95.3 °F	AI8 -0.7 °F	AI9 -192.6 °F	AI10 337.1 °F	AI11 1166.6 °F	AI12 1378.5 °F				
	AI13 7.80 %	AI14 21.87 %	AI15 35.93 %	AI16 64.07 %	AI17 78.13 %	AI18 92.20 %				
Event	Math1 -613.8	Math2 -665.6	Math3 -294.1	Math4 -93.4	Math5 219.5	Math6 477.0				
Status	Math7 92.2	Math8 78.1	Math9 64.1	Math10 85.9	Math11 71.9	Math12 57.8				
Exit	Dump	Clear	Operate	Config						Shutdown

Figure 3 – 2

3.2 Mode

Press **Mode** key to select the different ways of displays, which include Mix, Trend, Bar or Digital mode.

Mix: The display default is Mix mode. Several modes including horizontal/ vertical trend, bar and digital modes can be mixed together.

Trend: Press **Mode** key, to display Trend mode. This is measured data trend in real time. The same page/display may have a maximum of 6 trends in different colors. The user may define each color, details in **4.2 Display**.

Bar: Press **Mode** key again, to display bars in different colors. The scale of each bar can be defined individually, details in **4.2 Display**.

Digital: Press **Mode** key again, to display digits in different colors. Press **Mode** key again, to return to the original Mix mode.

3.3 History

Press **History** key, to display historical trend. Press directional keys ← → to backward or forward. Press **Zoom** key to zoom in the time scale. The Zoom can be done variously in 1 sec/dot, 1 hour/Page, 12 hours/Page, 1 day/Page or 1 week/Page. Press **Back** key going back to the original display.

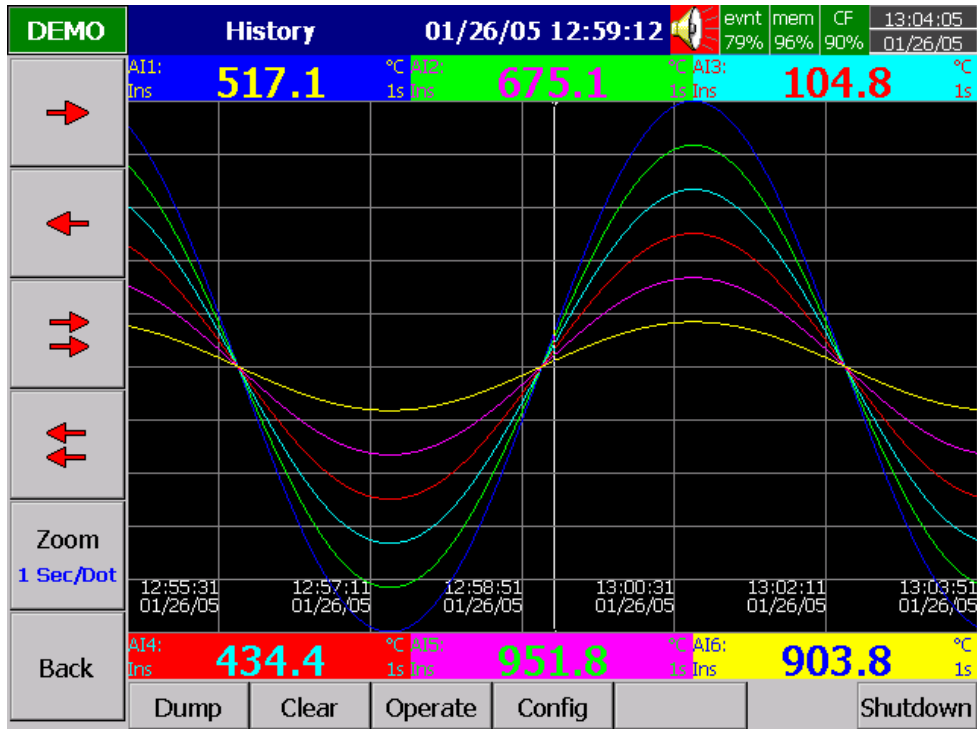

Figure 3 – 3

3.4 Event

Press **Event** key, the Event /Alarm List displays general Events, Alarms and Reports. Press **Mode** key to choose Evnt/Alam (Event/Alarm) or Report.

Event/Alarm

It displays the Ack (acknowledgement), Type, Source, Active time, Clear time and Value of events or alarms. Use directional keys ↓ ↑ to move downward or upward. Press **Ack** key to acknowledge the alarm. Events do not need to be acknowledged. Press **Back** key going back to the original display.

Ack	Type	Source	Active Time	Clear Time	Value
1	System	PowOff	11/21 14:44:28		
2	System	PowOn	11/21 14:44:28		
3	System	PowOff	11/21 14:46:46		
4	System	PowOn	11/21 14:46:46		
5	LoAlarm	AI7	11/21 14:46:49		-175.9
6	LoLoAlarm	AI7	11/21 14:46:49		-175.9
7	LoAlarm	AI8	11/21 14:46:49		-83.1
8	LoLoAlarm	AI8	11/21 14:46:49		-83.1
9	LoAlarm	AI9	11/21 14:46:49		-219.9
10	LoAlarm	AI13	11/21 14:46:49		0.80
11	LoLoAlarm	AI13	11/21 14:46:49		0.80
12	LoAlarm	AI14	11/21 14:46:49		17.20
13	HiAlarm	AI17	11/21 14:46:49		82.80
14	HiAlarm	AI18	11/21 14:46:49		99.20
15	HiHiAlarm	AI18	11/21 14:46:49		99.20
16	HiAlarm	AI1	11/21 14:47:35		781.8
17	HiAlarm	AI2	11/21 14:47:45		1060.5
18	HiHiAlarm	AI1	11/21 14:47:48		864.7
19	HiHiAlarm	AI2	11/21 14:48:06		1176.0
20	HiAlarm	AI3	11/21 14:48:06		270.8
21	HiAlarm	AI13	11/21 14:48:16		80.80
22	LoAlarm	AI18	11/21 14:48:16		19.20
23	HiHiAlarm	AI13	11/21 14:48:23		87.80

Figure 3 – 4

On the Event / Alarm List, three different colors indicate the status of the alarm.

- Red - Presently in alarm status.
- Green – The cause of alarm status was temporary, and has now returned to normal.
- Grey – A temporary alarm (in green status), after having been acknowledged, and then becomes grey.

Active Time is the time that alarm status becomes active. **Clear Time** is the time when two conditions are met. Firstly alarm status is cleared and becomes normal, and secondly the user has acknowledged it. If any alarm occurs, the red buzzer icon on the top right starts to flash. After the cause of alarm is no longer met and the alarm is acknowledged, then the red buzzer icon disappears. When Clear Time shows **Terminated** this indicates that turning off the power has terminated the alarm.

Report

Press **Mode** key to choose Report. This mode is only available after the option of Math, Counter, Totalizer & FDA 21 CFR part 11 was ordered before. It produces reports about Counters 1-6, Totalizers 1-18, AI1-AI18 MinMaxAve(Minimum, Maximum and Averaged values of analog inputs in certain period of time), Math1-Math18 MinMaxAve and All CH MinMaxAve. Press **Report** key to select it as Report List (all reports within a day, for example 3 reports for 3 shifts a day), or select it on daily, weekly or monthly base. Press directional keys to choose the exact day, week or month.

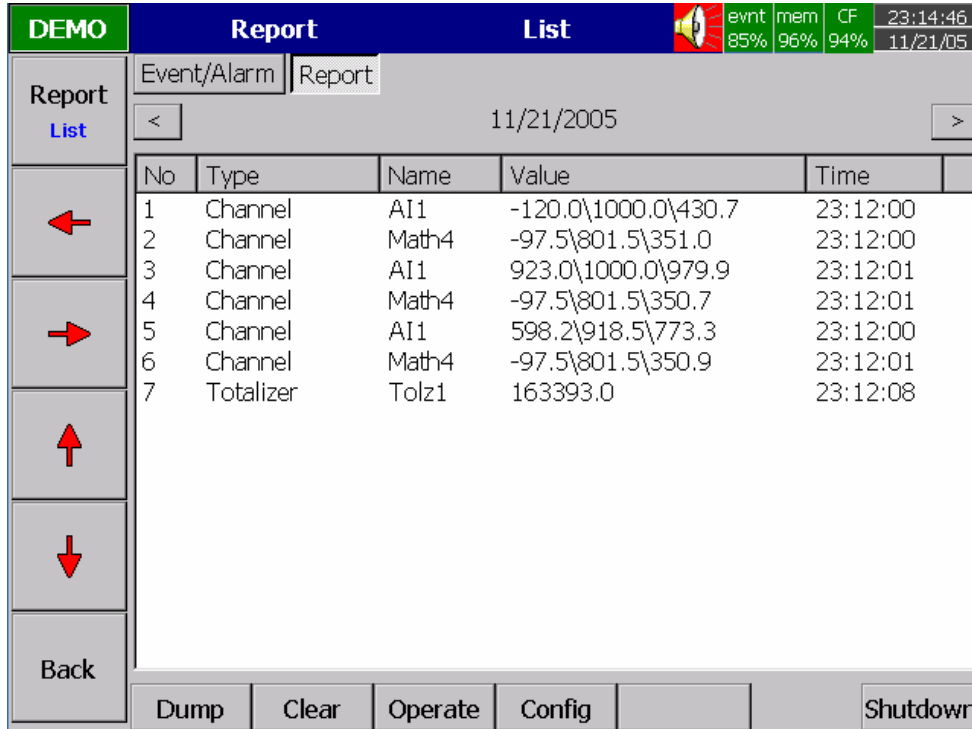

No	Type	Name	Value	Time
1	Channel	AI1	-120.0\1000.0\430.7	23:12:00
2	Channel	Math4	-97.5\801.5\351.0	23:12:00
3	Channel	AI1	923.0\1000.0\979.9	23:12:01
4	Channel	Math4	-97.5\801.5\350.7	23:12:01
5	Channel	AI1	598.2\918.5\773.3	23:12:00
6	Channel	Math4	-97.5\801.5\350.9	23:12:01
7	Totalizer	Tolz1	163393.0	23:12:08

Figure 3 – 5

3.5 Status

Press **Status** key, the Status List displays *present status* of digital input DI, digital output DO (alarm relay), Counter and Totalizer. Press **Mode** key to choose any mode of DI, DO, Counter or Totalizer. Display shows the status DI, DO, Counter or Totalizer *at the present time*. Counter and Totalizer are available if the option of Math, Counter & Totalizer was ordered before.

3.6 Exit

Press **Exit** key to close existing operation, the soft keys on the left hand side disappear giving full display. Press any soft key on the left hand side, these six soft keys **Page, Mode, History, Event, Status** and **Exit** appear again. Open the plastic cover at the front low side then another five soft keys **Dump, Clear, Operate, Config & Shutdown** appear.

3.7 Dump

Before removing the CF card from the recorder, it is necessary to press the **Dump** key to transfer the measured data and events from the internal memory of the recorder to the CF card

3.8 Clear

If the internal memory goes down to 25%, the mem icon on the top right changes color from green to red. Also, when the internal memory reserved for events is down to 25 %, the evt (event) icon on the top right changes color from green to red. In each case the user should transfer all the measured data from the recorder to CF card by pressing **Dump** key as above. However, if the measured data and events are not significant information, the user may also press **Clear** key to clear them.

3.9 Operate

Press **Operate** key to start a job manually. For example: to record the alarm by selecting **Log alarm**. There are various jobs that may be assigned, as described in **Event, Job** of **4.1 Channel**.

Details about soft key **Config** are described in **4. Configuration**.

3.10 Shutdown

Accidental turning off the power will cause loss of data and will interrupt the operation of the recorder. Therefore press the **Shutdown** key to shutdown the system first before turning off the power.

3.11 Logout

If a user orders the option of FDA 21 CFR part 11 compliance, and selects this type of high security, an extra Logout key appears next to Config key. It is used to record the logout time of the user. Only after the previous user logout from the recorder, the next user may log into the recorder.

3.12 Small icons (on the top right side):

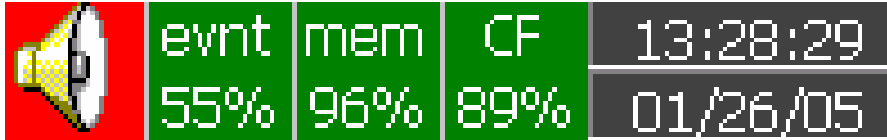

Figure 3 – 6

Buzzer: Appears by flashing in red whenever the alarm status occurs. The buzzer will disappear after the user acknowledges the alarm, and the process becomes normal.

Evnt: The percentage of memory space left for events/alarms. For example, evnt 84% means 84% space left for events/alarms. Refer to Event/Alarm Limit in **4.4 Instrument**. Various numbers of events/alarms can be set. The icon flashes red when memory space is down to 25%. The icon returns to normal green after pressing the soft key, either **Dump** or **Clear**.

mem: It is the percentage of memory space left for measured data. The icon starts flashing red when the memory space is down to 25%. The icon becomes normal green after press soft key either **Dump** or **Clear**. *If the internal memory goes down to 10 %, the earliest measured data and events will be saved to CF card in small batch automatically. If there is no CF card inserted, then the earliest measured data and events will be overwritten and replaced by the latest measured data and events.*

CF: The icon shows the status of Compact Flash card. If the CF card is not inserted, the icon shows a red-cross sign. If it is properly inserted, then the icon displays normal green and indicates the percentage of the memory space left on the CF card. The icon starts flashing in red when the memory space goes down to 25%. The icon becomes normal green again after downloading data and events from the CF card to PC. *If the CF card is inserted in the recorder and its memory is full, then the memory of CF card remains unchanged and the earliest measured data and events on the recorder will be overwritten and replaced by the latest measured data and events.*

Date/Time: To set the local time, please refer to **4.5 Clock**.

4. Configuration

Press the **Config** key to enter the Configuration mode. The following buttons appear: Channel, Display, Tools, Instrument, Clock, System Info and Demo. Meanwhile, the following soft keys appear at the bottom: Save, Load, Default and Back.

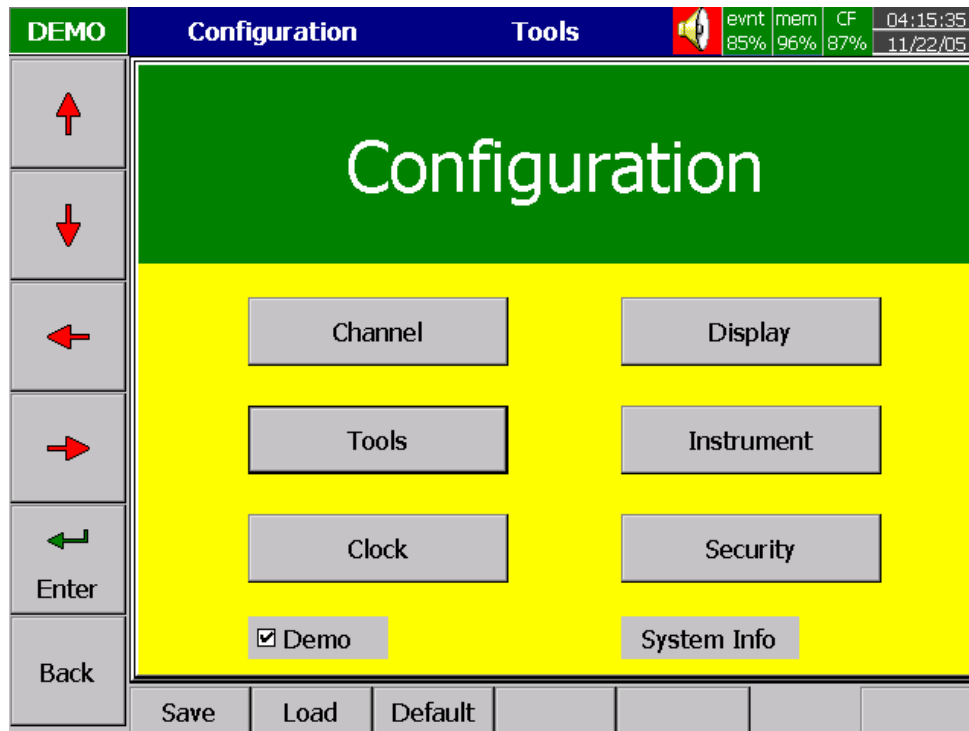

Figure 4 – 1

Soft Keys

Enter: First select the mode by pressing directional keys , then press **Enter** key to enter any mode of Channel, Display, Tools, Instrument, Clock, System Info or Demo.

Save: Save configurations from recorder to storage media CF card. *To read the configuration and measured data from CF card on a PC for the first time or any time configuration has been changed, it is important to press Save key to save configuration changes to CF card beforehand.*

Load: Load configuration from storage media CF card to recorder.

Default: If the configuration is set incorrectly, Default is a useful key to recall the default settings on the analog input card inserted into rear expansion slot.

Back: Go back to the previous display.

4.1 Channel (Analog input, Digital input, Analog output, Math input)

Analog input

After entering the Configuration mode, select **Channel** and press the **Enter** key to get into Channel mode. It displays the Analog input **AI** first. Press directional keys at the bottom to select the channel. Afterwards, press directional keys on the left hand side to select the column. *After Configuration 4.1 to 4.8, press Back key to return to real-time display, all configurations will be memorized.*

No	Type	Setpoint	Job 1	Job 2	Hysteresis
1	H	80.00	Log Alarm	No Action	Off
2	L	20.00	Log Alarm	No Action	Off
3	HH	87.50	Log Alarm	No Action	Off
4	LL	12.50	Log Alarm	No Action	Off

Figure 4 – 2

Name: It is to define the name for each channel in maximum 6 characters. Press **Enter**, a keyboard and several keys appear. **BackSP** key means backspace, **Select** key means to select a character or number, **Caps on** means characters in capital, and **Caps off** means characters not in capital.

Desc: The description about a specific channel on the display.

Log Method: The method of logging measured data. Select the column, and then choose the Log method of Instant, Average, Minimum or Maximum data.

Disable: *Select Disable while a specific channel is not required at this time.*

Instant: logging in the last measured data at the sampling interval

Average: logging in averaged measured data at the sampling interval

Minimum: logging in minimum measured data at the sampling interval

Maximum: logging in maximum measured data at the sampling interval

Log Speed: It is the logging speed (recording speed) of measured data. Select Log Speed column, then choose 1, 2, 5, 10, 30, 60 or 120 seconds.

Offset: It is offset value to correct the sensor error.

Gain: It is a multiplier to correct the sensor error.
The correct value = (the process value + offset) x gain

Sensor: It displays automatically the setup input of V, mV, mA, T/C (J, K, T, E, B, R, S, N, and L), PT100, and JPT100. The default setting is 4-20mA if no other input specified.

Unit: The engineering unit of input.

Range: Various input ranges can be set for voltage and current. Normally, it sets 0-1, 1-5, 0-5 or 0-10 V for the voltage, and set 0-20 or 4-20mA for the current.

Scale Unit: Defines the scale unit.

Scale Low: Defines the low scale *with decimal if necessary*. For instance, input 0-10 V, the Scale Low can be set up with value 0.00 to be correspondent to low range 0 V.

Scale High: Defines the high scale *with decimal if necessary*. For instance input 0-10 V, the Scale High can be set up with value 100.00 to be correspondent to high range 10 V.

Event

The Event is frequently used for **Alarm** purpose. Event can also be used for digital output DO, Timer, Totalizer, Counter or Report.

Type: There are various types of H, L, HH, LL, R or r to be selected for **job or Alarm** purpose.

H: High limit. When the process is over high limit, the alarm or job is actuated.

L: Low limit. Any the process is lower than low limit, the alarm or job is actuated

HH: High high limit, to set up another limit higher than high limit for double warning.

LL: Low low limit, to set up another limit lower than low limit for double warning.

R: Increasing rate of change. The job or alarm is actuated when the rate of increasing process value is greater than the specified rate time interval. For example, when the Setpoint is set to 100_1S, if the process is increasing greater than the value 100 in 1 second, then job or alarm will be actuated.

r: Decreasing rate of change. The job or alarm is actuated when the rate of decreasing process value is greater than the specified rate time interval. For example, when the Setpoint is set to 50_2S if the process is decreasing greater than the value 50 in 2 seconds, then job or alarm is actuated.

Setpoint: To set up the process value for actuating Job1 and /or Job2

Job1, Job2: When an event occurs, the task to be performed is called the job. A typical example is to trigger **an alarm buzzer** in event of high temperature. Each pen can accept four events (or alarms) and each event can create two jobs. Please note that a job under Event is different from a job by pressing the

Operate key. The former is actuated by an event, and the latter is actuated by manual control, no event necessary.

Various types of jobs can be selected:

No Action: Do nothing.

Log Alarm: Record alarms

Log Event: Record events

Stop logging: Stop logging data.

Start logging: Start logging data.

Sound Buzzer: Sound the buzzer. It stops once any key is pressed.

DO Latch On: Set digital output / relay on, and then select Target from DO 1 to DO 6. The relay is latched when it is activated.

DO Latch Off: Set digital output / relay off, and then select Target from DO 1 to DO 6. The relay is latched when it is activated.

DO Process: Set digital output / relay on for process high or low, and then select Target from DO 1 to DO 6. The relay is not going to be latched when it is activated.

Enable Timer: Start the timer, and then select Target from Timer 1 to Timer 6.

Disable Timer: Stop the timer, and then select Target from Timer 1 to Timer 6.

Preset Totalz: Start the totalizer with a preset value, then select Target from Tolz 1 to Tolz 6.

Reset Totalz: Reset totalizer into zero, and then select Target from Tolz 1 to Tolz 6.

Enable Totalz: Start the totalizer, then select Target from Tolz 1 to Tolz 6.

Disable Totalz: Stop the totalizer, then select Target from Tolz 1 to Tolz 6.

Preset Counter: Start the Counter with a preset value, then select Target from Cont1 to Cont6.

Reset Counter: Resets the counter into zero, and then select Target from Cont1 to Cont6.

Inc Counter: Increase the counter, and then select Target from Cont1 to Cont6.

Dec Counter: Decrease the counter, and then select Target from Cont1 to Cont6.

Log Report: Make the report for Counter and Totalizer. Choose this column, and then the report will be presented as details described in **3.4 Event**.

Reset MinMaxAve: In Report function, after logging the MinMaxAve data of AI and Math channels for one day for example, then reset historical data in order to logging new data for the next day.

Hysteresis: To avoid it been activated too often, the relay can set for no reaction in 0.1% to 10% of full span (Low Scale to High Scale).

Note:

- ◆ The sampling rate of the recorder is fixed at 200 milli seconds by the hardware, i.e. samples 5 measured data per second.. If the logging speed is set at 1 second in Instant mode, the recorder logs using the last of five measured data values. For the same speed in Averaging mode, the recorder logs using the average of the five measured data values. For the same speed in the Maximum or Minimum mode, then the recorder logs using the maximum or minimum of the five measured data values..

	Sampling	Logging (historical trend)	Display (real time)
Instant	200mS	the last of 5 measured data	the last of 5 measured data
Averaged	200mS	the average of 5 measured data	the last of 5 measured data
Maximum	200mS	the maximum of 5 measured data	the last of 5 measured data
Minimum	200mS	the minimum of 5 measured data	the last of 5 measured data

Press Back key to return to real-time display, all configurations will be memorized

The **Digital output DO card with 6 relays** can be set in Job1, Job2. It can be traced in **System Info** mode after installed into the Slot.

Digital input

Press **DI** key to select the Digital input. Define the name, Description, and set up the Event accordingly. Press directional keys at the bottom to select the channel.

Analog output

Press **AO** key to select the Analog output. Define Output either 0-20mA or 4-20mA if it is current output card AO183I. Define Output either 0-5V, 1-5V or 0-10V if it is voltage output card AO183V. Then define Expression and range. The sources of Expression cover analog inputs, Math inputs and Counters.

Math input

Press **Math** key to select the Mathematics input. Except for Expression, it is similar to do the setting up for Analog input above. Define the name, Description, and select Type, Log Method, Log Speed, Unit, Scale Low, Scale High, and Event. Enter Expression column, it appears Source, Operator and a keyboard. The Source covers all available Analog inputs, Math inputs and Counters. The Operators are Mathematics expressions described below. Use Source, Operator and keyboard to define the Math equation. Press directional keys at the bottom to select one from 18 available Math. Press **Back** key to memorize the Math settings.

The screenshot displays the configuration interface for a Math input. At the top, a status bar shows 'DEMO' and 'Math Math15' along with system metrics: 'evnt 48%', 'mem 96%', 'CF 88%', and a timestamp '14:11:50' with date '01/26/05'. Below this is a row of 18 numbered buttons (8-18) with left and right navigation arrows. The main configuration area contains the following fields:

- Name: Math15
- Desc: (empty)
- Type: Disabl (dropdown)
- Log Method: Instant (dropdown)
- Speed: 1 S (dropdown)
- Expression: HI(AI3,AI9/2.0)
- Unit: (empty)
- Low: -3276.8
- High: 3276.7

An 'Event' section contains a table with 4 rows and 6 columns:

No	Type	Setpoint	Job 1	Job 2	Hysteresis
1	No (dropdown)	0.0	Log Alarm	No Action	Off (dropdown)
2	No (dropdown)	0.0	Log Alarm	No Action	Off (dropdown)
3	No (dropdown)	0.0	Log Alarm	No Action	Off (dropdown)
4	No (dropdown)	0.0	Log Alarm	No Action	Off (dropdown)

At the bottom, a navigation bar includes '<', '>', 'AI', 'DI', 'Math', and 'Back' buttons. A left sidebar contains an 'Enter' key and directional arrows.

Figure 4 – 3

If the Math option been ordered, the following Math functions are available in the Channel mode of configuration. The equation is used to produce derived variable by using measured data or computed data as variable. The result of Math can be displayed and stored. The Math expression / equation can be keyed in maximum 36 characters.

Math Expressions and an example

Expressions on recorder	Mathematics Functions
+	Addition
-	Subtraction
*	Multiplication
/	Division
SIN(x)	$\sin(x)$
COS(x)	$\cos(x)$
EXP(x)	e^x
SQRT(x)	Square root of x
LN(x)	$\log_e(x)$
TG(x)	$\tan(x)$
CTG(x)	$1/\tan(x)$
ASIN(x)	$\sin^{-1}(x)$
ACOS(x)	$\cos^{-1}(x)$
ATG(x)	$\tan^{-1}(x)$
LOG(x)	$\log_{10}(x)$
ABS(x)	Absolute of x
SQ(x)	x^2
ROUND(x)	The closest integral number to x
HI(x,y)	The bigger value between x and y
LO(x,y)	The smaller value between x and y
INV(x)	$1/x$
PCT(x,Hi,Lo)	$PCT \% = x / Hi - Lo$, x: Target Value, Hi: High Value, Lo: Low Value
$x\%y$	Remainder of x/y
x^y	x^y
POW (x,y)	x^y

Note:

- ▲ To add the option of Math, Counter & Totalizer on recorder, it is necessary to order a Boot ROM with this option. Then, open the housing and replace the Boot ROM.

An example of Math

Three AI analog inputs and one Math channel. Set up a Math channel after setting up three analog inputs. In **Channel** mode as **4.1 Channel**, press **Math** key to get into Math channel. Define the Name, Description, enable Type, define Log Speed, Log Method, and do Math Expression / Equation. Then, select **Display** mode as **4.2 Display**. Define mode, Trend Direction, Background color. If Pens 1, 2, 3 have been used for three analog inputs, then select Pen 4 to be used for Math. Press **Enter** key under **Channel** column of Pen 4, then select MATH1. Define Color, Width of trend, DisplayHi and DisplayLo. Press **Back** key twice to return to the beginning of display all configurations will be memorized. Then the Math starts working.

4.2 Display

Press the **Back** key to return to the beginning of the Configuration mode. Select **Display** and press **Enter** key to get into Display mode. Display may have a maximum 6 Pages and each Page may display maximum 6 channels.

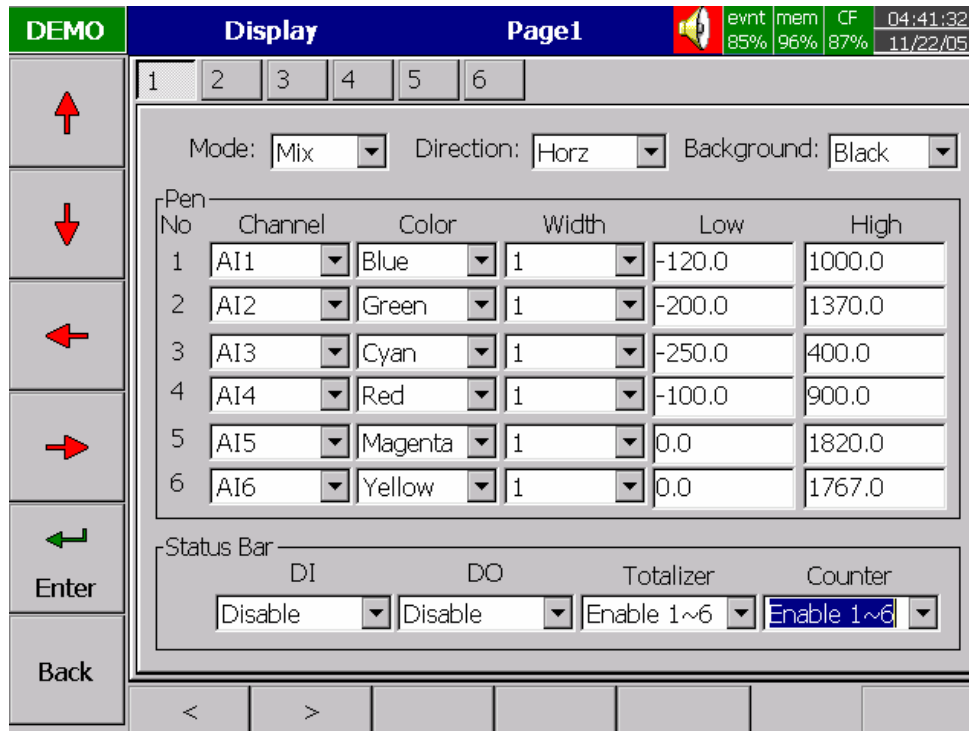

Figure 4 – 4

Mode: Defines the method of displaying data. Options are: Mix , Trend, Bar or Digital modes.

Direction: Selects the trend direction horizontal or vertical.

Background: Defines the background color of Trend mode in black or white

Pen: Defines a specific channel as a drawing pen, its color, width, DisplayHi and DisplayLo.

Channel: Selects a specific analog input AI or Mathematics Math, or selects Disable if a specific channel is not required.

Color: Selects the color for each pen.

Width: Selects the width of trend, 1-thin, 2-medium, 3-wide.

Low: Defines the low scale for a pen on the display.

High: Defines the high scale for a pen on the display.

StatusBar: To make it convenient when viewing the status of Totalizer, Counter, DI or DO, the user may enable these items in the StatusBar. For example, after enable Totalizer 1 6 and Counter 1 6, two extra bars of Totalizers and Counters will appear at the lower part of display.

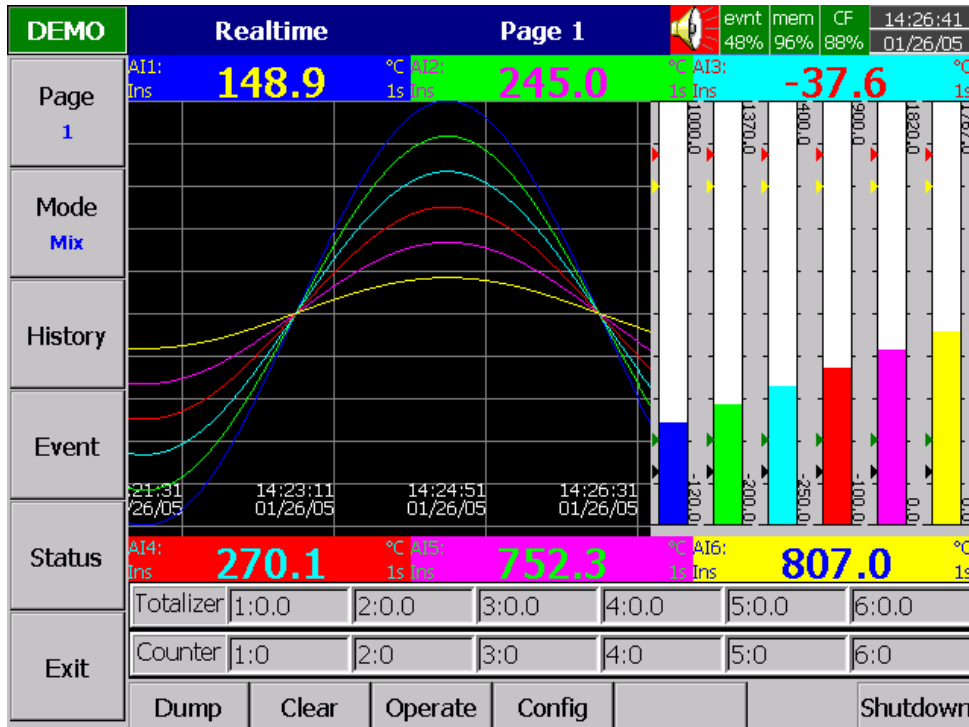

Figure 4 – 5

Note:

To illustrate the difference between DisplayHi, DisplayLo and Scale Hi, Scale Low. Here is a typical example, with input 0-10V, Scale Low=0.00, Scale Hi=100.00, to have better resolution and vision on Bar, set DisplayLo=0.00, DisplayHi=50.00 so that the Bar displays from value 0.00 to 50.00.

The decimal point is defined by Scale Hi and Scale Low, and not by DisplayHi, or DisplayLo.

4.3 Tools (Timer, Counter & Totalizer)

Press **Back** key, to return to the beginning of Configuration mode. Select **Tools**, then press **Enter** key to get into Tools mode. Timer, Counter and Totalizer are defined here. *Counter and Totalizer are available only if the options of Math, Counter & Totalizer have been ordered before.*

Timer

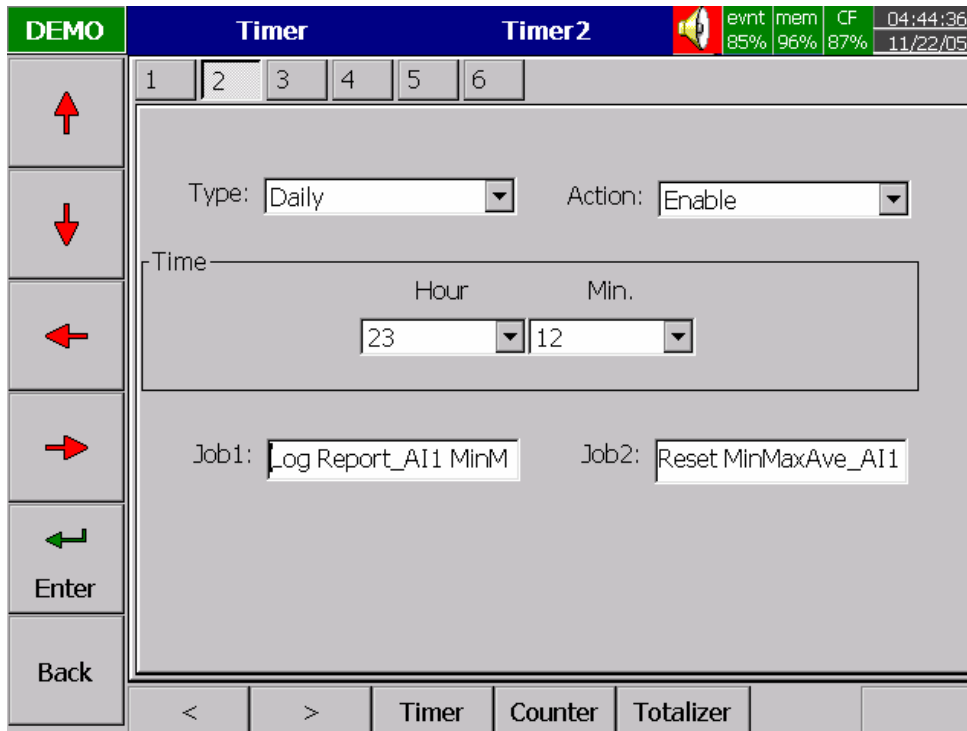

Figure 4 – 6

Press directional keys at the bottom to select one from 6 available timers.

Type: Countdown, Repeat Countdown, Daily, Weekly or Monthly.

Countdown: Defines the interval of time, e.g. days, hours, minutes and seconds. (not Real Time)

Repeat Countdown: Repeats the previous countdown.

Daily, Weekly or Monthly: The timer works in selected interval of Real Time.

Action: Disables or enables the timer.

Job1, Job2: various jobs as described in 4.1 Channel, 2 jobs for each timer.

An example of Timer & Report: A staff plans to get a daily report from the recorder about the minimum, maximum and average values of the process every day. He needs to get into **Tools** mode of Configuration and do the following settings. After the production has finished, he can press **Event** key on the left hand side, and press **Mode** key to select **Report Daily** mode and get the report like **Figure 4-7**.

Timer1 to Timer 6:

Type: Daily Action: Enable

Time – Hour: 17 Min: 01

Job1: Log Report Target: AI1 MinMaxAve (to AI6 MinMaxAve)

Job2: Reset MinMaxAve (Reset historical data in order to logging new data for the next day.)

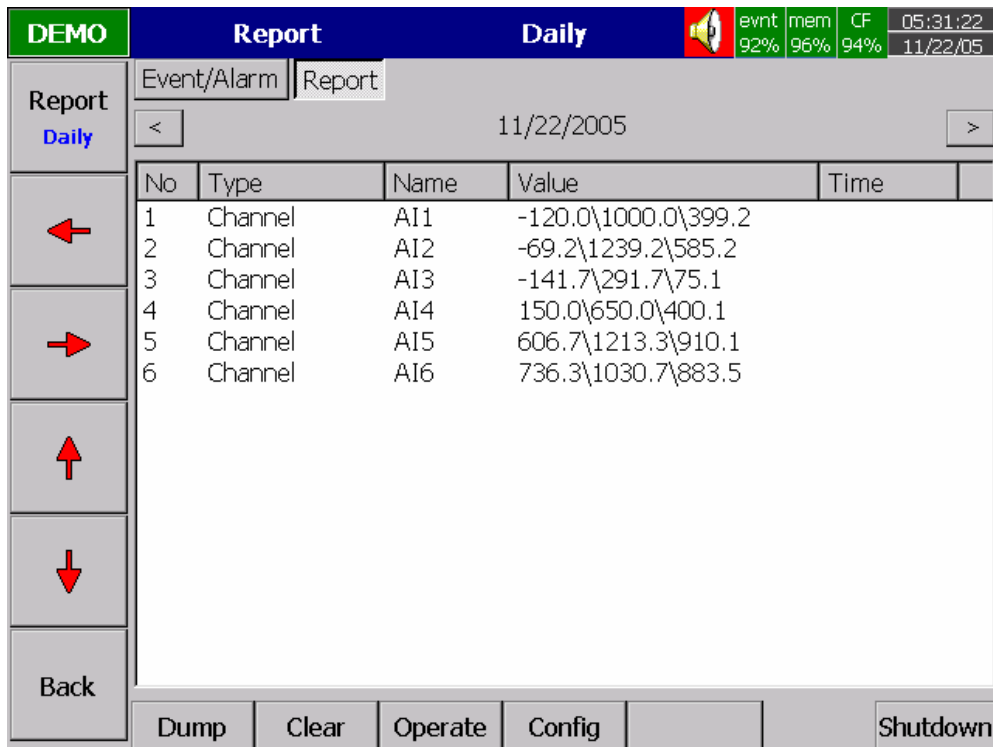

Figure 4 – 7

Counter

DEMO		Counter		Cont1		evnt	mem	CF	05:44:39
						85%	96%	94%	11/22/05

Type	Setpoint	Job 1	Job 2
H	600	Log Report_Cont1	No Action
L	100	Log Alarm	No Action

Figure 4 – 8

Press directional keys at the bottom to select one from 6 available counters.

Name: Defines the name of counter.

Desc: Defines the description for a specific counter on the display.

Unit: Defines the unit of counter

Preset: Defines the preset value for the counter. The counter starts from a preset value.

Event: Defines the type, setpoint, Job1 or Job2.

Type: Select one of three options: None, Process Hi, Process Low

Setpoint: Defines the set point of process value to trigger the counter.

Job1, Job2: various jobs as described in 4.1 Channel, 2 jobs for each counter

Totalizer

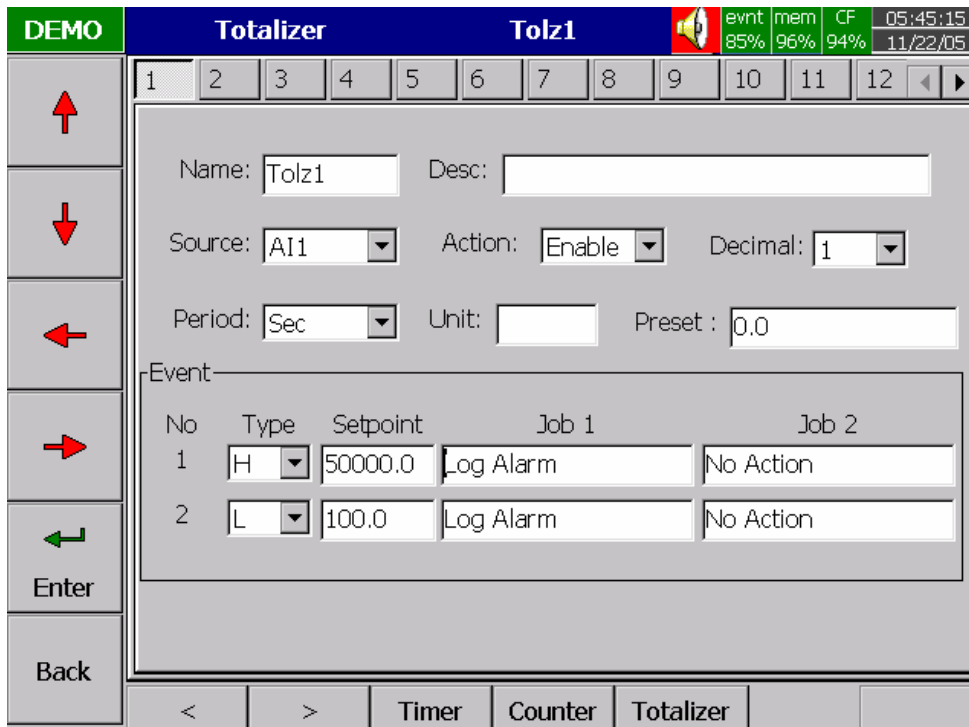

Figure 4 – 9

Press directional keys at the bottom to select from 18 available totalizers.

Name: Defines the name of the totalizer.

Desc: Defines the description for a specific totalizer on the display.

Source: Select a specific analog input or Math input to be used for totalizing.

Action: Disables or enables the totalizer.

Decimal: Defines the decimal point for the totalizer.

Period: Selects second, minute or hour used for the totalizer.

Unit: Defines the unit of totalizing

Preset: Defines the preset value for the totalizer. The totalizer starts from a preset value.

Event: Defines the type, setpoint, Job1 or Job2.

Type: Select one of three options: None, Process Hi, Process Low

Setpoint: Defines the set point of process value to trigger the totalizer.

Job1, Job2: various jobs as described in **4.1 Channel**, 2 jobs for each totalizer.

An example of Totalizer: A factory operates for 8 hours a day, and the staff wish to get the total volume of production from daily, weekly and monthly reports. First, the user needs to enter into **Tools** mode, do the settings as follows, then totalizer starts to work from 8:30 am, and stops at 17:30 pm daily. After production has finished, the user does the following: press **Event** key on the left hand side, and press **Mode** key to select Report mode. Finally, press **Report** key to choose daily, weekly or monthly report.

Timer1

Type: Daily Action: Enable

Time: Hour: 8 Min: 30

Job1: Reset Totalz Target: Tolz1

Job2: Enable Totalz Target: Tolz1

Timer2

Type: Daily Action: Enable

Time: Hour: 17 Min: 30

Job1: Log Report Target: Tolz1

Job2: Disable Totalz Target: Tolz1

Timer3

Type: Weekly Action: Enable

Time: Hour: 17 Min: 31

Job1: Disable Timer Target: Timer1

Job2: Disable Timer Target: Timer2

Timer4

Type: Weekly Action: Enable

Time: Hour: 8 Min: 00

Job1: Enable Timer Target: Timer1

Job2: Enable Timer Target: Timer2

Totalizer

Name: xxxx Desc : xxxxxxxxxxxxxxxxxxxxx

Source: A11 Action: Enable Decimal: 1

Period: Min Unit: xxxx Preset: 0.0

Event

No	Type	Setpoint	Job1	Job2
1	High	xxxx	Log Alarm	Set DO Process
2	Low	xxxx	Log Alarm	Set DO Process

The daily, weekly or monthly report indicates Totalizer data of each day, each week or each month respectively.

4.4 Instrument

Press **Back** key, to return to the beginning of Configuration mode. Select **Instrument** then press **Enter** key to get into Instrument mode.

The screenshot displays the 'Instrument' configuration menu. At the top, a status bar shows 'DEMO' in a green box, 'Instrument' in a blue box, and system metrics: 'evnt 84%', 'mem 96%', 'CF 94%', '05:48:51', and '11/22/05'. A navigation sidebar on the left contains buttons for Up, Down, Left, Right, Enter, and Back. The main configuration area is titled 'Instrument' and contains the following settings:

- Name: Demo
- Language: English
- Event Limit: 256
- Security: Normal
- Data Transfer: Dump and
- Keypad Sound: Minimum
- LCD Screensaver: 10Min.
- Sensor: Off & On: Keypad
- Communication: PC Transfer: Ethernet, IP: User Define
- IP Address: 192.168.0.111
- Subnet Mask: 255.255.255.0
- Default Gateway: 0.0.0.0

Figure 4 – 10

Instrument

Name: Assigns a name for the recorder in maximum 8 characters.

Language: Languages of English, Chinese (simplified), Chinese (traditional), Japanese, Korean, French, German, Italian, Polish, Spanish, Russian and Thai are all available.

Event Limit: Selects the highest possible numbers 256, 512 or 1024 for events (including alarms).

Security: Select Normal or CFR-21 security. The normal security allows different users to key in a common password. The higher security CFR-21 is complied with FDA 21 CFR part 11. It is a much higher security to define each user as Supervisor or Operator with different authority to access the recorder and using different passwords. It has time limit too during operation. 10 minutes hand off from keys, the user needs to key in password again. It also offer audit trail function to record the user, the timing and what type work he was doing on the recorder before, details explained in **4.6 Security & FDA 21 CFR part 11 compliance**.

Data Transfer: Select Dump and Clear if the user wishes to clear the data on recorder after dumping data to PC or CF card. Select Transfer and remain if the user wishes to remain the data on recorder after transferring data to PC or CF card.

Keypad Sound: Selects the following four options: disable, minimum, medium or maximum

LCD:

Screensaver: To prolong the life of the LCD display, it is suggested to set the display turn-off time in 1, 10, 20, 30, 40, 50 or 60 minutes after the user operates the recorder. *It was initially set 10 minutes for Screensaver from the factory.* The recorder continues to recode data while it is in the screen saving mode. The display turns on again by pressing any soft key or by Infrared sensor. When an alarm occurs, it turns on the display as well.

Sensor:

Off & On: Keypad - Turn off & on by keypad. If the Screensaver is set 10 minutes, the display turns off 10 minutes after hands off from the recorder, and it turns on again after the user presses the keypad.

Off & On: IR – Turn off & on by infrared sensor. If it is the same Screensaver setting, the display turns off 10 minutes after the user away from the recorder, and it turns on again when the user approaches the recorder within 2 meters.

Off: IR, On: Keypad – Turn off by infrared sensor, and turn on by keypad. If it is the same Screensaver setting, the display turns off 10 minutes after the user away from the recorder, and it turns on again after the user presses the keypad.

Note:

To use infrared IR sensor on recorder is a genius idea to prolong the lifetime of LCD display. It senses the movement of body temperature when a user gets closer or walks away. (distance in about 2 meters).

Communication

PCTransfer: Selects RS-232/RS-485/RS-422, or standard Ethernet communication.

RS-232, RS-485, RS-422:

Address: 0 to 247 nodes for RS-485

Baud Rate: Selects it from various Baud rates 1200, 2400, 4800, 9600, 19200, 38400, 57600 or 115200.

Data Format: Selects it from three different data formats.

Ethernet:

IP: Select **Automation** if the server on the network automatically allocates the IP address for the recorder. Select **User Define** to manually set a fixed address for the recorder. Two new columns will appear for keying in fixed addresses

IP Address: Defines the correct address of the recorder on the network

Subnet Mask: Defines the correct **SubnetMask** address on the network

Default Gateway: Different Gateway has different IP address on Ethernet.

Note:

- ▲ If Automation is selected, the IP address and SubnetMask are invisible. IP address can be found in **4.8 System Info** mode under Configuration. Because *the server could reallocate a new IP address after power off and on*, the user defining fixed addresses is recommended.

4.5 Clock

Press **Back** key, to return to the beginning of Configuration mode. Selects **Clock** then presses the **Enter** key to get into Clock (Date/Time) mode to set up the local time.

Date Style: Selects either month/date/year or date/month/year

Date/Time: Set up the local time. Use directional keys going to the **Apply** column, and then press the **Enter** Key to apply it to the recorder.

Summer time: For energy saving concern in certain area, it can be enabled and set certain period of time for the purpose of energy saving in the summer.

The screenshot displays the 'Clock' configuration interface. At the top, a status bar shows 'evnt 84%', 'mem 96%', 'CF 85%', and the current time '12:28:31' and date '11/22/05'. The main area is titled 'Clock' and contains three sections: 'Date Style' (set to 'mm/dd/yy'), 'Date/Time' (Date: 11/22/05, Time: 12:28:12), and 'Summer time' (set to 'Disable' with a range of 04/01 ~ 09/30). An 'Apply' button is located below the Date/Time section. On the left side, there is a vertical navigation menu with arrows for up, down, left, and right, and buttons for 'Enter' and 'Back'.

Figure 4 – 11

4.6 Security & FDA 21 CFR part 11 compliance

In **4.4 Instrument**, in column Security select Normal or higher security CFR-21. If the normal security is selected, for different users it needs just to key in a common password in maximum 8 characters. Once the password has been entered, the user needs to key in the password whenever **Config**, **Dump**, **Clear** or **Operate** soft keys are required. These keys enable the user to do configuration, dump data, clear data or manually operate the job. For easy access **Config**, **Dump**, **Clear** or **Operate** soft keys, the user may ignore the password.

If the higher security CFR-21 is selected, it is required to operate the recorder in more restricted rules which are complied with **FDA 21 CFR part 11**. This higher security defines two types of users including Supervisor and Operator with different authority to access the recorder by using different passwords as Figure 4-12. It has time limit during operation. If hands are off from keys in 10 minutes, the user needs to key in password again. It also offers audit trail function to record the user, the timing and what type work he was doing on the recorder before. Incorrect password and unauthorized operation will be recorded into the event list as well.

The screenshot shows a security configuration interface. At the top, there is a status bar with 'DEMO' on the left, 'Security' and 'User1' in the center, and system metrics on the right: 'evnt 41%', 'mem 96%', 'CF 38%', '17:23:25', and '11/24/03'. Below the status bar is a numeric keypad with buttons 1 through 12 and navigation arrows. The main area contains the following fields:

- User:
- Password:
- Security Level:
- Time of validity:
- Days of expiration:

At the bottom, there are 'Enter' and 'Back' soft keys, and a row of navigation buttons including left and right arrows.

Figure 4 – 12

Security level:

Supervisor: The top Supervisor can define all the user names including other Supervisors and Operators total in 30 numbers including him. He can access all the keys too, and his Time of validity for the password is unlimited.

Operator: He can access vertical keys to view the historical data, events and status but no authority to access horizontal keys to do configuration, neither to dump, clear data.

Time of validity:

If the Time of validity of any user been defined as 30, 60 or 90 days valid account, it means that the account will be closed after 30, 60 or 90 days. If it is defined as 30, 60 or 90 days valid password, then it will request the user to key in a new password, or remain the old one after 30, 60 or 90 days.

4.7 Demo

The Demo mode is a simulation mode used as a sales tool for demonstration purposes. It was set to simulate 18 AI analog inputs, 12 Math, 6 DI digital inputs and 6 DO digital outputs. *To start the automatic demonstration, first enable Demo mode, then turn the power off and on to make it effective. To stop the automatic demonstration and return to real mode with real inputs, first disable Demo mode, then turn the power off and on.*

4.8 System Info

The system information includes System version, memory, CF card, Ethernet IP address and Slots status.

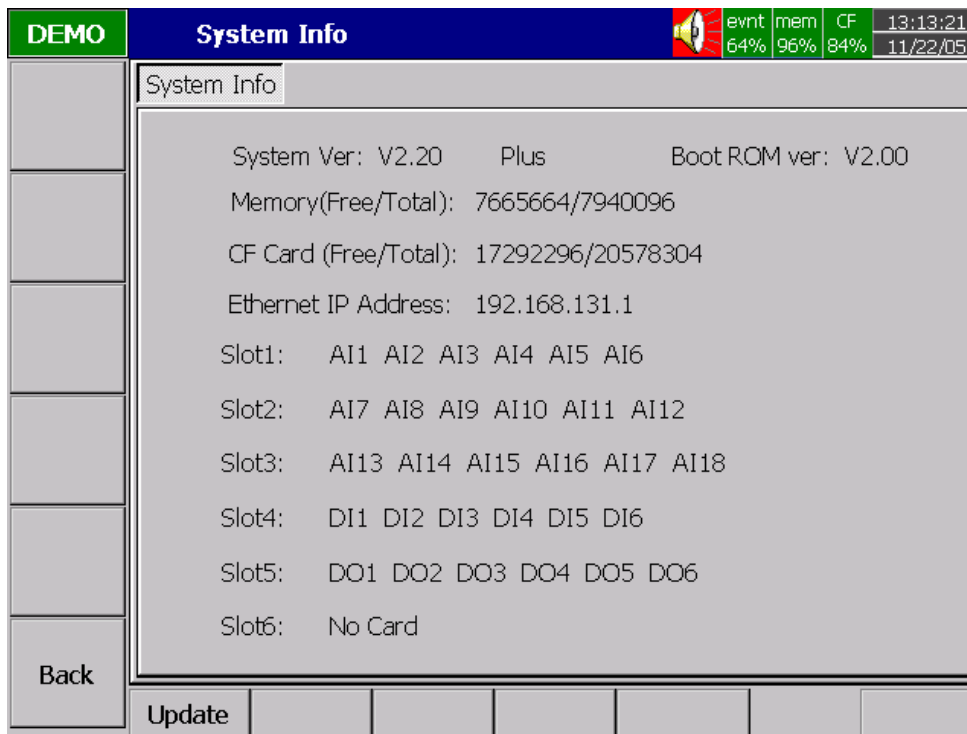

Figure 4 – 13

System Ver: It is the firmware version of the recorder. V2.20 means the present firmware version of recorder. Plus means with the option of Math, Counter, Totalizer & CFR-21.

Boot ROM ver: It is version of Boot ROM.

Memory (Free / Total): Indicates the percentage of free memory to total memory reserved on the recorder. 8 MB memory on board is reserved for storing measured data. A small icon on the top right indicates the percentage of free memory e.g.: mem 96 % .

CF Card (Free / Total): Indicates the percentage of free memory to total memory of the Compact Flash card. e.g. CF 84%.

Ethernet IP Address: It is the present IP address of the recorder.

Slot 1..6: Indicates the status of all Slots and the cards been inserted in. The cards include Analog Input AI, Digital Input DI and Digital Output DO (6 relay card).

Update: The Update key is located at left lower side. It is the key to upgrade the new firmware. After the new firmware downloaded to the CF card, insert the CF card in. Then, press this key to upgrade it. It may take a few seconds to finish the process.

4.9 A configuration example

Here is a process required for a paperless recorder with 3-channels of 4-20mA input, 6-relay outputs and Ethernet communication for real-time monitoring. With, Analog input card **AI183**, not yet fitted into rear slot, set up 4-20mA input according to **2.3 Setup input and output cards**, and then plug it into rear SLOT 1. Plug 6-relay output card **DO181** into rear SLOT 2. Do the wiring and installation onto panel. Set up the extensive PC software **Observer II** to PC, then power on the recorder. Open the front cover at the bottom side, and then 5 soft keys appear. Press **Config** key to do Configuration. Press **Enter** key to get into **Channel** mode. Do settings according to **4.1 Channel**. Define the names for each channel, choose Log speed 1S, Method Instant, Range 4.000 20.000, Scale Unit %, ScaleLo 0.00 and ScaleHi 100.00. Define the Event (alarm) High alarm H for Channel 1, 2 & 3, and define Job1 with Log alarm. Then, do the rest of the settings according to **4.2 Display**, **4.3 Tools**, **4.4 Instrument** and **4.5 Clock**. If the IP address of the recorder is fixed for Ethernet communication, (not automatically assigned by the server), then the user needs to define IP as User Defined. Then set up the IP address and Subnet Mask in **4.4 Instrument**. The recorder is now ready for real-time monitoring and data acquisition.

If the user needs no communication and wishes to read measured data from the CF card on a PC, then set up the basic software **Observer I** in the PC, and add a CF card reader on USB port of PC. *To read the configuration and measured data on CF card for the first time, it is necessary to press the Save key to save configurations first*, and then press the **Dump** key to Dump measured data from the recorder to CF card before inserting it into the CF card reader. *If any configuration has been changed, it is necessary to press both keys before inserting the CF card into the reader.* If the configuration remains unchanged, to dump measured data press the **Dump** key, do not press **Save** key again. After that, the measured data can be seen in trend or Excel format on PC. A 128 MB CF card is supplied free.

5. PC software and Communication configuration

5.1 Observer I & Observer II PC software guide

This is simple guide for PC software. Please refer more details to the software user manual in the HELP of PC software itself.

Observer I & II are the PC software used for the recorder.

Observer I contains two components

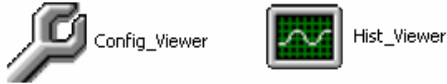

Observer II contains three components



CONFIG_VIEWER is for configuration of the recorder from PC.

HIST_VIEWER is for monitoring historical trends in PC.

REAL TIME_VIEWER is for real time data logging in PC.

Observer I is supplied along with the recorder at free of cost.

Observer II is supplied on additional charge for real time data logging applications through PC.

System requirements

Hardware

PC with Minimum 200 MHz processor, 64 MB RAM
100 MB free space in the hard disk.
RS 232 serial port/ Network adopter RJ 45 female/ USB port and CF reader

Software

Operating system: Windows 98, Windows ME, Windows XP, Windows NT & Windows 2000.

Install Observer Software

Run the setup exe available at CD supplied and follow on screen instructions. At any point of time only one either observer I or observer II will exist in any PC. If user install new version of observer software, old version will be deleted automatically during installation of software.



Config_Viewer



Hist_Viewer



RealTime_Viewer

Uninstall Observer Software

This is to remove Observer software from PC. Observer I or Observer II may be uninstalled from PC any time from the following two ways

Control panel- Add/remove programs-observer I/observer II

Start –Programs–Observer I / Observer II / Uninstall

CONFIG_VIEWER



Config_Viewer

This is used for configuration of the recorder from PC.

Start-Programs–Observer I / Observer II–Configuration

Tool bar



To open new project



To open existing project file



To save the project file settings in PC



To delete the project file from PC



To select bank (CF card/ Ethernet / RS 232)



To select the channel (AI/AO/DI/DO/MATH)



To select display



To select tools (Timer/Counter/ Totalizer)



To select instrument details





To select system information (Type of cards available at slots, system version info)



Clock summer settings

 To set password

 Receive configuration (CF reader/RS 232/Ethernet)

 Send configuration (CF card/RS 232/Ethernet)

If Observer software is already configured in the PC, then you can select *.prj file to open the project.

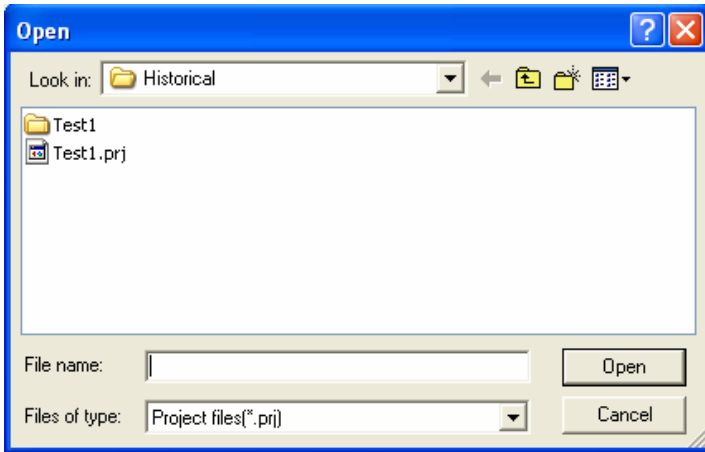

For the first time configuration you can cancel the above window and select new project



Enter the name of the project.

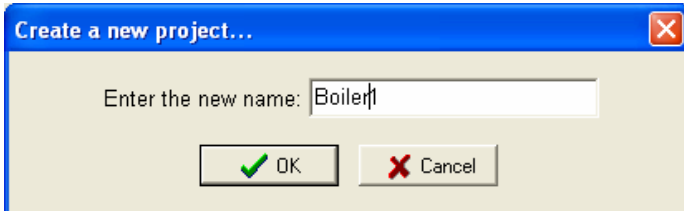

Bank

This is used to select physical connection between the recorder and PC.

Three options are available

1. CF card
2. Ethernet
3. RS 232

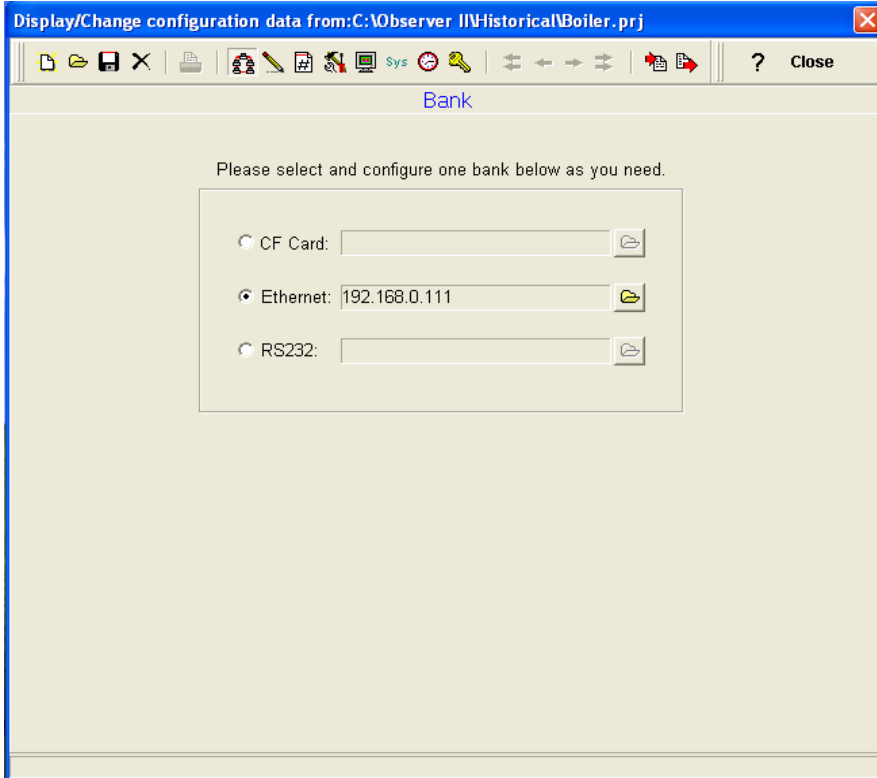

128 MB CF card shall be supplied along with the recorder. Standard Ethernet port (RJ 45 female) shall be available at the recorder. RS 232/ RS485 shall be supplied as additional options.

5.2 Ethernet Configuration

It is possible to use PC software Observer II for data logging from multiple units of recorders connected on standard Ethernet. Total number of devices that can be connected depends on the hardware interface selected for the application. For example, 255 hardware devices can be connected on Ethernet. Maximum 1024 tags can be configured at Observer II for data logging, archiving and analysis. The tags cover AI, Math, DI, DO, Counter & Totalizer.

1. Make sure that network adapter in PC is properly configured. IP address, Subnet mask and Gateway should be configured at the PC for using Observer II program. Please contact System administrator to set Unique IP address for the PC.
2. Install Observer II application software in PC. The software may be installed from setup available in the CD supplied as per the order.
3. Ethernet configuration at Recorder

Please refer to **4.4 Instrument** entering IP address, subnet mask and gateway address manually at the recorder.

Gateway refers to a device on a network that sends local area traffic to other networks.

Subnet mask numbers help to define the relationship between host and rest of the network.

For every LAN, the Network administrator shall define Subnet mask and Gateway. Obtain subnet mask and gateway address for the LAN at the place where the recorder to be connected. Enter these details at the Recorder manually using front buttons.

By default, subnet mask address: 255.255.255.0

By default, Gate way: 0.0.0.0

Allocate the Unique IP address to the recorder and enter IP address at the recorder manually. Contact System administrator for obtaining free IP address available at user LAN. Naming duplicate IP address may disable the communication between the recorder and PC/LAN HUB.

4. Local area network uses UTP cable for Ethernet connectivity. Maximum UTP cable distance between the recorder and LAN/HUB/PC should be less than 100 Meters. If the distance is more than 100 Meters, additional LAN accessories/equipments may be required for increasing signal strength. Please contact network administrator for more information on extending LAN.
5. Two different types of cables shall be used for connecting the recorder on Ethernet as follows. For connecting the recorder to LAN HUB, then standard straight-through Ethernet cable should be used. For connecting the recorder to PC/Notebook directly, then crossover Ethernet cable should be used.

Straight Through Cable VR18-LAN/HUB	
RJ-45 PIN	RJ-45 PIN
1 Tx+	1 Rc+
2 Tx-	2 Rc-
3 Rc+	3 Tx+
6 Rc-	6 Tx-

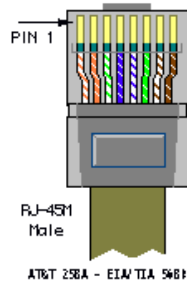

Crossover Cable VR18-PC/Notebook	
RJ-45 PIN	RJ-45 PIN
1 Rx+	3 Tx+
2 Rc-	6 Tx-
3 Tx+	1 Rc+
6 Tx-	2 Rc-



- Connect proper UTP Ethernet cable as per the requirements and observe the communication status between the Recorder and PC/LAN HUB at the LED's dedicated for the purpose near female RJ 45 connectors.

Recorder side

Link (Green LED)

Green lit: Cable connected between the recorder and PC/LAN HUB

Green Off: No Link between the recorder and PC/LAN HUB

Tx/Rx

Orange Lit continuous: No cable connection

Orange slow blink: Communication established between recorder & PC/LAN HUB

- If the communication between the recorder and PC/LAN HUB is successful, then start Observer II in the PC as follows

Start-Programs-Observer II – Configuration

For the first time, Under Historical folder .prj file shall not be available.

Open new file 

Enter new name for the project, Ex: Boiler

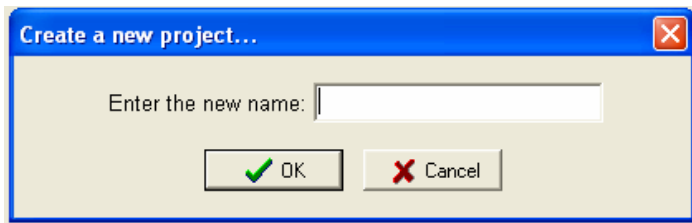

Select Ethernet in the Bank by using radial button

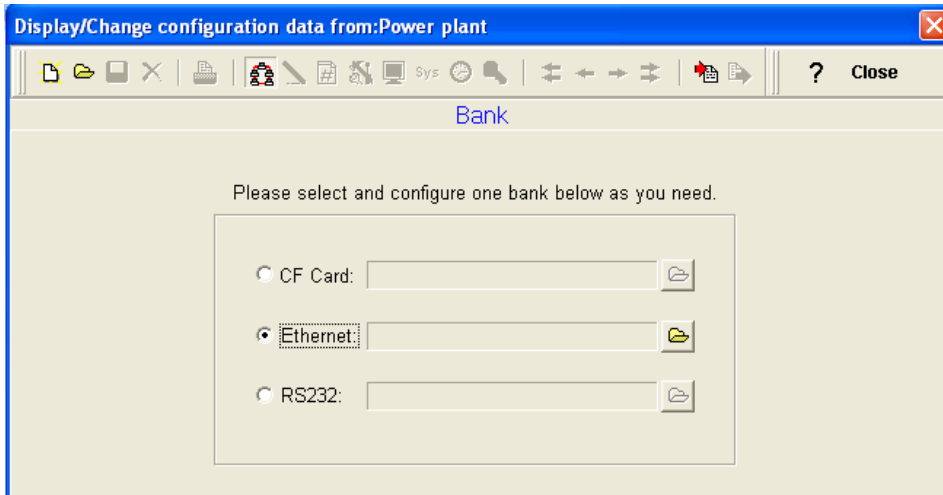

Open for Ethernet connection 

Enter the IP address of the Recorder

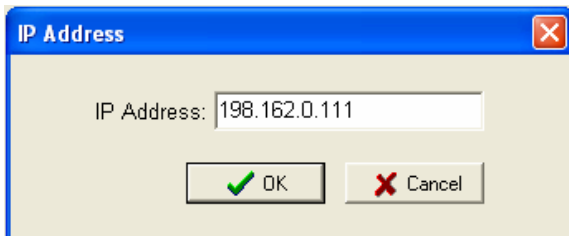

System will ask "Do you want to receive configuration data now? (Y/N)"

Click on "Yes" to upload the recorder configurations to PC.

If Upload is successful, it shows message as “Configuration successful” and all the configuration settings of the recorder now available at PC. The information includes all channel details of Input/Output cards as per Jumper/switch settings.



If Upload is unsuccessful, it shown message as “No response from Recorder, connection fails”.

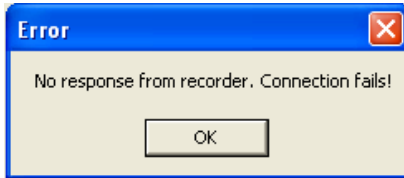



If this is the case, please check the Ethernet cable connections at both the recorder and PC/LAN HUB side. Also make sure that green communication LED available for proper firm connection at RJ 45 connector.

If still communication is not established between the recorder & PC, then once again check Subnet mask and gateway address at the recorder & PC. Contact Network/ System administrator for proper Ethernet configuration of the recorder & PC. Please note that recorder should have unique IP address in the network and PC being used for Observer II shall have separated Unique IP address in the network.

5.3 RS 232, RS485, RS422 Configuration

It is possible to use PC software Observer II for data logging from multiple VR18 recorders connected on network RS 485. Total number of devices that can be connected depends on the hardware interface selected for the application. For example, 247 hardware devices can be configured on RS 485. Maximum 1024 tags can be configured at Observer software for data logging, archiving and analysis. The tags cover AI, Math, DI, DO, Counter & Totalizer.

1. Make sure that RS 232 port is available at recorder. Normally it will be D9 male.
2. Also make sure that RS 232 port available at PC where observer software is installed.
3. Please refer to **2.5 RS 232/RS 485/ RS 422 wiring** in details.
4. Set RS 232 communication settings at the recorder manually. Please refer to **4.4 Instrument** and select RS 232 at PC transfer. Set RS 232 communication details manually at the recorder. Please note that press Back Key to save the changes at the recorder. Switch off the recorder power supply, then switch on once again and make sure that RS 232 communication details are properly saved in the recorder.
5. Connect RS 232 cable between the recorder and PC. Please refer to **2.5 RS-232 wiring** details.
6. Select RS 232 in the bank as below through radial button  RS232.
7. Click on  for RS 232 communication settings.

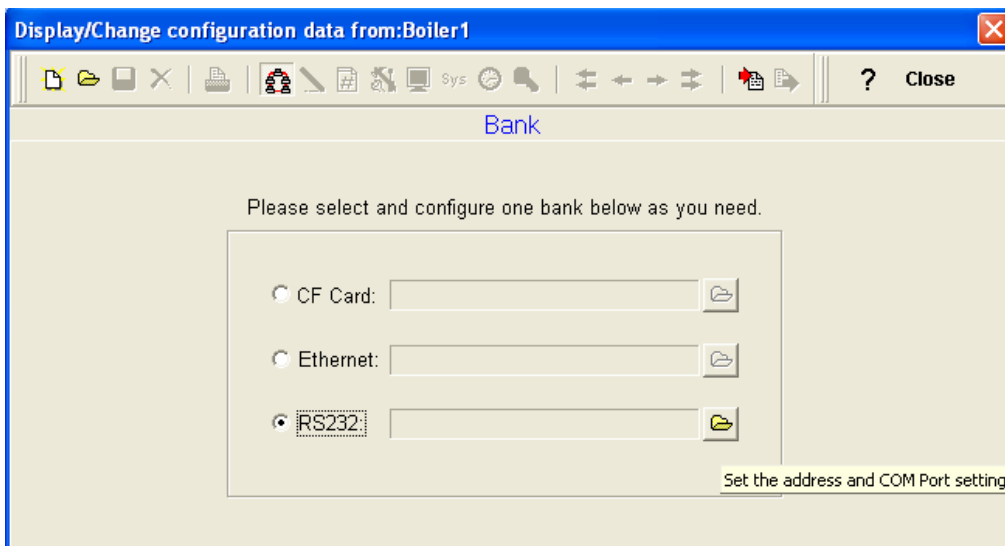

8. Set communication parameters for RS 232 communication at PC.

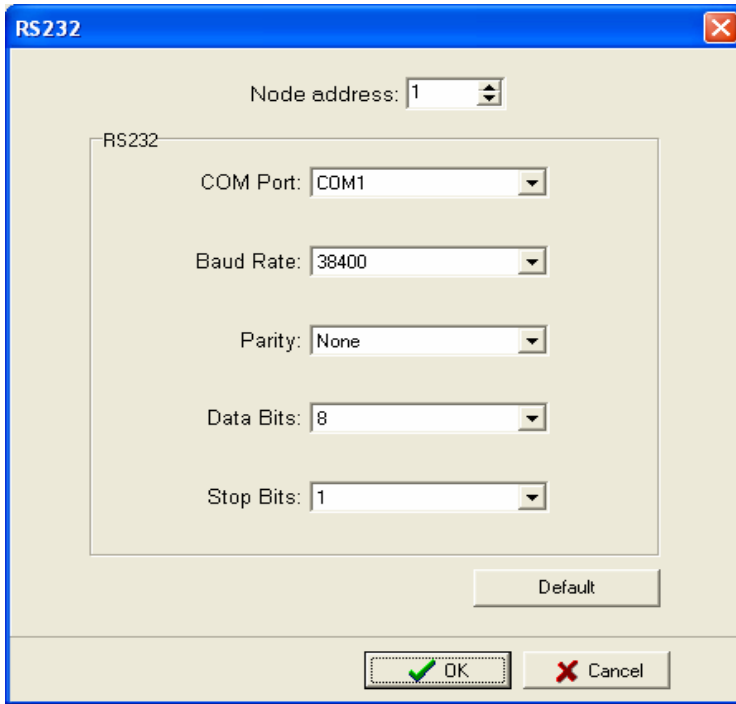

9. Click on OK after setting all above details. By default Node address is 1. If any change is there for the node address, then it should be set at recorder manually then enter the same node address in the above configuration.

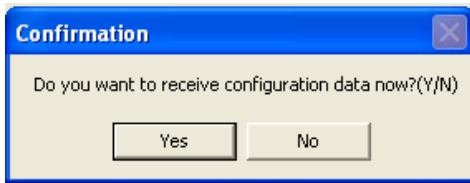

10. Click on “Yes” to upload the recorder configurations to PC.

11. If Upload is successful, it shows message as “Configuration successful” and all the configuration settings of VR18 recorder now available at PC. The information includes all channel details of Input/Output cards as per Jumper/switch settings.

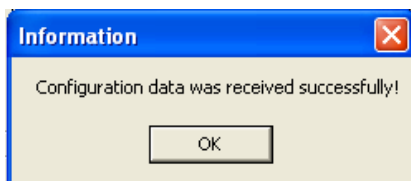

If Upload is not success, it shown message as “No response from Recorder, connection fails”.

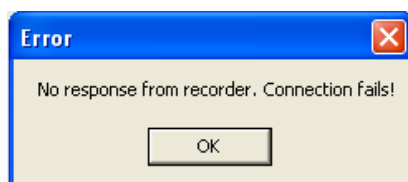

If this is the case, please check the RS 232 cable connections at both the recorder and PC. Also make sure that green communication LED available for proper firm connection at back RS 232 port available at recorder back side.

If still communication is not established between the recorder & PC, then once again check Node address at the recorder. If more than one recorder is connected in RS 485/ RS 422 network, make sure that all the devices have unique address. Check the communication settings at the individual recorders manually.

If the converter SNA 10A is used for converting RS 485/ RS 422 to RS 232, then make sure that Dip-switches are correctly set for the communication details.

If RS 485/ RS 422 is used for connecting recorders, then make sure that last node is less than 1000 meters from the PC. Also make sure that STP cable is being used for RS 485 connections.

In some computers, COM 1 and COM 2 have been used for other devices. So it is required to carefully check whether RS 232 cable is connected to proper communication port of PC or not.

It is important to check COM port of PC to see whether it been properly set.

My computer-Properties-Hardware-Device Manager – Ports – COM 1 – Properties

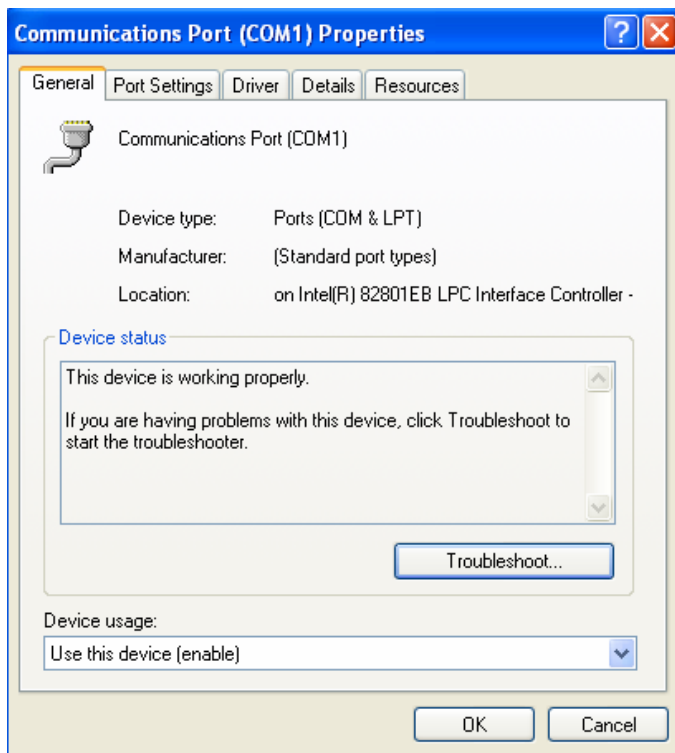

Device usage: It should be enabled

Device status: The device is working properly.

If above conditions are not met, then RS 232 port is having problem at PC. Contact system administrator for replacing the port or updating driver properly.

If still communication is not established, user can try setting up observer software in another PC where COM port is healthy.

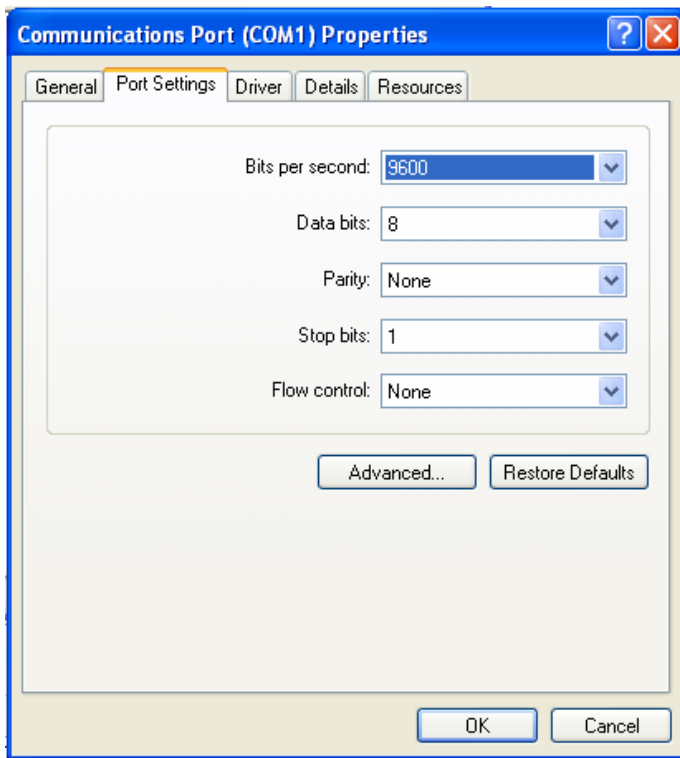

Make sure that RS 232 communication setting at the recorder and PC are equal.

5.4 CF card Configuration

1. If no other higher capacity CF card been ordered, the standard 128 MB CF card shall be supplied along with the recorder.
2. Save configurations from recorder to CF card at Recorder.
Configuration – Save.
This step will make sure that all IO cards information as per jumper and Dip-switch selection will be saved in to the CF card.
3. Use CF reader to read the recorder configuration on CF card in Observer software. Normally CF readers are available for use at USB port.

Please note that all standard CF readers from major vendors will be detected automatically as mass storage devices by the Win XP operating system. If you are using any other operating system like Windows 98, windows ME, Windows NT and Windows 2000, then mass storage device may not be detected and you have to install the driver for the CF reader. Driver CD shall be shipped along with Observer software for configuration of CF card at PC. Please note that, you need to configure CF card driver only if operating system not detecting mass storage device.

4. Once CF reader along with CF card are detected by the PC, then it should appear as removable drive at the computer.
5. Start Observer program, Ex: Start-Programs-Observer 1 - Configuration

Open new file 

Enter new name for the project, Ex: Boiler

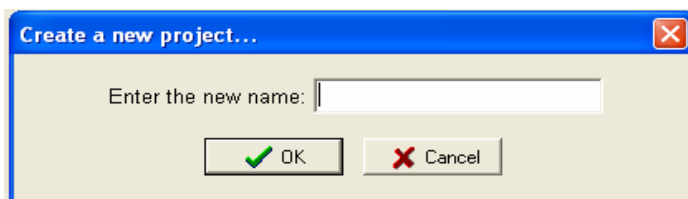

6. Select CF card using radial button

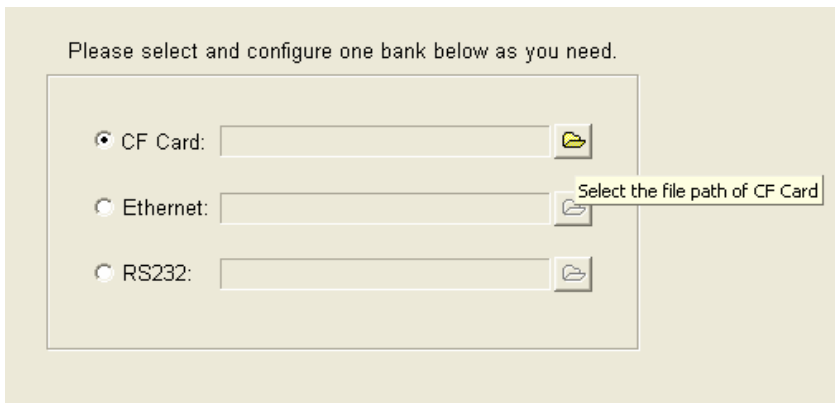

7. Click on  to set CF path to receive the configuration data available in CF card.

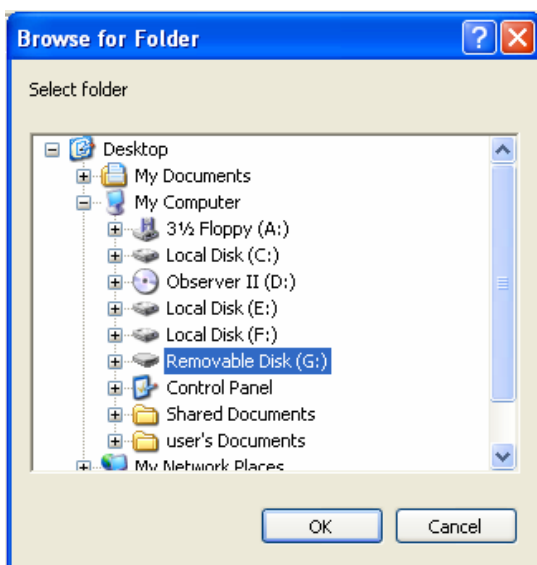

8. Click on Yes to receive the configuration data from CF card to PC.

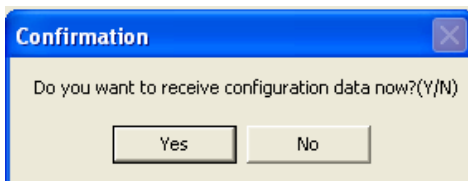

9. If Upload is successful, it shows message as “Configuration successful” and all the configuration settings of the recorder now available at PC. The information includes all channel details of Input/Output cards as per Jumper/switch settings.

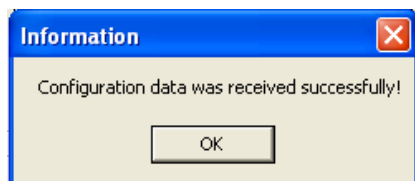

10. If Upload is unsuccessful, it shown error message as “Configuration file does not exist”. This message indicates that configuration information is not available in the CF card. Check correct path of CF card is selected.

If still problem exists, check the files available in the CF card at PC. At least 2 files by name IO and RECORDER should be available. If the files are not available, then recorder configuration data is not properly saved in the CF card. Repeat it from Step 2.

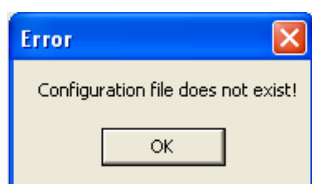

5.5 Configuration in Real-Time Viewer



Configuration data

It is used to define the configuration of the recorder for Real-Time Viewer. Please note that the configuration of Real-Time Viewer can be redefined and independent to the configuration of recorder itself.

Tag Name	Bank	Node/IP	Tag Type	Device Type	Addr...	EngHi	EngLo	Unit	Deci...	Alarm1	SP1
AI1	1	192.168.0.111	VR18	Channel1		4553.6	-199...	°C	1	Hi	24.0
AI2	1	192.168.0.111	VR18	Channel2		4553.6	-199...	°C	1	No	
AI3	1	192.168.0.111	VR18	Channel3		4553.6	-199...	°C	1	No	
DI1	1	192.168.0.111	VR18	DI1		65535	0		0	No	
DI2	1	192.168.0.111	VR18	DI2		65535	0		0	No	
DI3	1	192.168.0.111	VR18	DI3		65535	0		0	No	
DI4	1	192.168.0.111	VR18	DI4		65535	0		0	No	
DI5	1	192.168.0.111	VR18	DI5		65535	0		0	No	
DI6	1	192.168.0.111	VR18	DI6		65535	0		0	No	
DO1	1	192.168.0.111	VR18	DO1		65535	0		0	No	
DO2	1	192.168.0.111	VR18	DO2		65535	0		0	No	
DO3	1	192.168.0.111	VR18	DO3		65535	0		0	No	
DO4	1	192.168.0.111	VR18	DO4		65535	0		0	No	
DO5	1	192.168.0.111	VR18	DO5		65535	0		0	No	
DO6	1	192.168.0.111	VR18	DO6		65535	0		0	No	
Cont1	1	192.168.0.111	VR18	Counter1		65535	0		0	No	
Cont2	1	192.168.0.111	VR18	Counter2		65535	0		0	No	
Cont3	1	192.168.0.111	VR18	Counter3		65535	0		0	No	
Cont4	1	192.168.0.111	VR18	Counter4		65535	0		0	No	
Cont5	1	192.168.0.111	VR18	Counter5		65535	0		0	No	
Cont6	1	192.168.0.111	VR18	Counter6		65535	0		0	No	
Tolz1	1	192.168.0.111	VR18	Totalizer1		4294...	0.0		1	No	
Tolz2	1	192.168.0.111	VR18	Totalizer2		4294...	0.0		1	No	
Tolz3	1	192.168.0.111	VR18	Totalizer3		4294...	0.0		1	No	
Tolz4	1	192.168.0.111	VR18	Totalizer4		4294...	0.0		1	No	
Tolz5	1	192.168.0.111	VR18	Totalizer5		4294...	0.0		1	No	
Tolz6	1	192.168.0.111	VR18	Totalizer6		4294...	0.0		1	No	

1 items selected

Double click on channel in the above spreadsheet to show the following Modify tag data with email configuration. If auto-update option is selected in modify tag data as shown in following screen, then all the settings done at the channel for events will appear here. If it is not selected, then user can configure manually for different set points in order to generating alarm emails.

Modify tag data ✖

Auto-update

Tag Type: DEMO Tag Name: AI1

Bank: 1 Device Type: Channel1

Protocol: Modbus_TCP LogSpeed: 1 S

IP Address: 192.168.0.111 LogMethod: Instant

Alarm		
Type	Setpoint	Job
1 Hi	24.0	Send Email
2 HIHI	26.0	Send Email
3 No		No Action
4 No		No Action

Engineering

High: 4553.6 Unit: °C

Low: -1999.9 Decimal: 1

Select Send email option for the job as shown above.

The Email on event will be received like this,

Type:HiAlarm
 Source:AI1
 ActiveTime:12/12/20059:49:59AM
 Value:23.8

 **Option** Three options of Share, Email and Communication are to be defined. It is mainly to set email configuration and real time log speed.

Option ✖

Share | **Email** | Communication

Please fill in the blanks so the email function can be activated.

SMTP Server

Host: company.com

Port: 25

User: Henry

Address

From : sales@company.com

To: service@company.com

service@company.com

Share: Share/do not share options are available for user selection. If share option is selected, then Observer data available in the computer can be shared from other computers. On selection of this share data, shared folder will be created in C:\Observer.

For example, you have one recorder and wish to analyze historical data at different computer. While opening project in the second computer, directly link to the project file available under C:\Observer through network configuration. This will minimize the data transfer between recorder and the computers and make it more efficient by using available resources through network configurations.

Email: The default Port number 25 is used to send email from SMTP server. If your network administrator configured different port in your LAN for accessing internet/email, then you have to modify the port number accordingly.

To send an email for any event, the procedure is as follows.

Set SMTP server details as below. Please contact system or network administrator for the server details if your computer is connected in LAN.

Host, Port, User name, From: Sender email address

To: Receiver email address (Max.10 email addresses can be selected)

Communication: It is used to set data display time for Real-Time Viewer. User can select one from the following for real time monitoring.

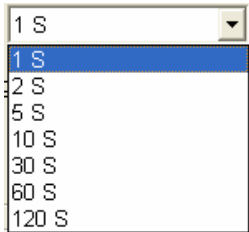

For example, if recorder and Observer are located at different places connected through Ethernet across different gateways, then user can set the communication time from this option. If 60 sec is set, then Observer will exchange data with the recorder once in 60 sec. When recorder and Observer are separated in far distance, it is preferable to use Ethernet option so that it can have better data transfer rate for communication.

 **Bank:** It is to modify the channel for communication between Recorder and Observer from Real-Time Viewer. Four banks are available. In each bank protocol options Disable, Modbus_RS232 and Modbus_TCP are available for user selection. This Bank is used for Real-Time Viewer only, which is different from the Bank used for recorder itself on Page 60.

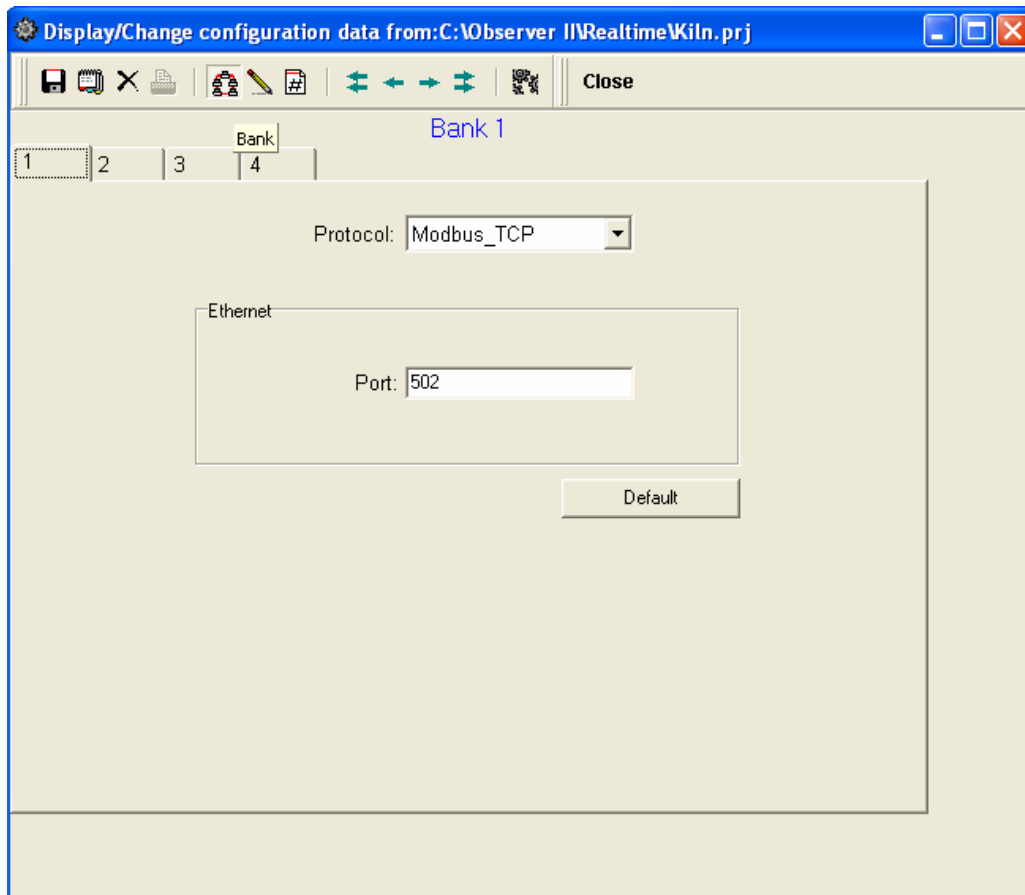

For Ethernet, Recorder uses port no. 502 for communicating with Observer. If you change the port number in Observer, you cannot establish communication between Observer and Recorder. Port no: 502 is used to establish communication between recorder and Observer software to exchange data on Ethernet over Modbus_TCP protocol.

5.6 DDE dynamic data exchange

DDE link

Dynamic Data Exchange (DDE) is a standard inter-application communication protocol built into Microsoft Windows operating systems and supported by many applications that run under Windows. DDE takes data from one application and gives it to another application. It allows Windows programs that support DDE to exchange data between themselves.

Data from the Observer II software can be exchanged with **Excel** on DDE link.

Please note that it is not possible to exchange data directly from the recorder to third party applications like Excel. Once Observer II software is installed with real timer viewer and configured properly in PC, then it is possible to exchange data between Observer software and Excel using DDE link.

Open real time viewer from start – programs – Observer II – Real-time viewer

Project – create DDE link in excel

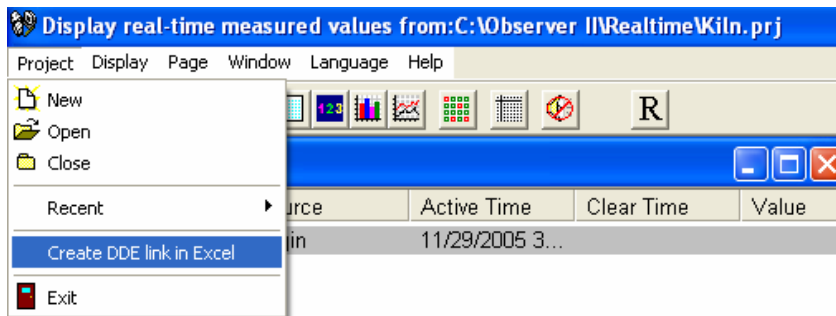

Specify the path and file name as follows.

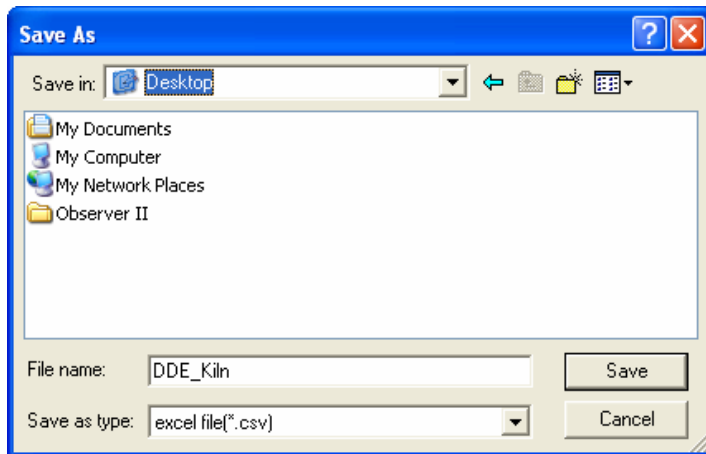

By default the file name will start with DDE and the project name with underscore in between to avoid confusion in naming the file. Save the file name in PC at selected path as above to proceed further. For example, if desktop is selected in the path, then the file should be available in the desktop. Please check up the desk top for the excel file.

If the MS Office is not installed in the PC, then you cannot open the excel file created as above procedure. Please contact your system administrator to install MS office software in the PC.

Now try to open the file from the desktop created for using DDE application with the recorder through Observer software.

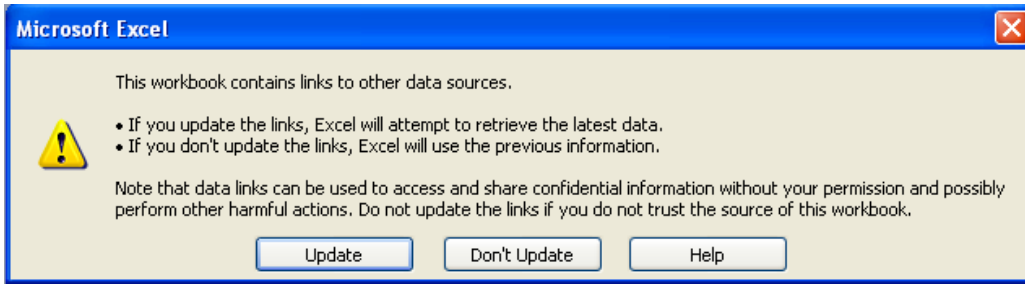

Click on update to activate DDE between Observer software and Excel application. If the DDE is successful, then real time data of the pens should be updated in excel file as shown in sample screen.

DDE expression format to get real time data from the Observer software is as follows.

```
=RealTime_Viewer|TagService!_A11
```

```
Application = RealTime_Viewer  
Topic = TagService  
Tag name = A11
```

Please note that every tag name will have underscore after “!” character. It is possible to exchange data related to AI, DI, DO, Counters and Totalizers between Observer software and third party applications running under windows operating systems visa DDE.

	A	B	C	D	E	F	G	H	I	J	K	L	M	N	O
1	Name	Unit	Value												
2	A11	°C	31.4												
3	A2	°C	ERROR												
4	A3	°C	ERROR												
5	D11		0												
6	D2		0												
7	D3		0												
8	D4		0												
9	D5		0												
10	D6		0												
11	DO1		0												
12	DO2		0												
13	DO3		0												
14	DO4		0												
15	DO5		0												
16	DO6		0												
17	Cont1		0												
18	Cont2		0												
19	Cont3		0												
20	Cont4		0												
21	Cont5		0												
22	Cont6		0												
23	Tolz1		0												
24	Tolz2		0												
25	Tolz3		0												
26	Tolz4		0												
27	Tolz5		0												
28	Tolz6		0												
29	Tolz7		0												
30	Tolz8		0												
31	Tolz9		0												
32	Tolz10		0												
33	Tolz11		0												
34	Tolz12		0												
35	Tolz13		0												
36	Tolz14		0												

If any “Error” test appears in any cell of Excel, possible reasons is no data available at selected tag. Check the data availability at the recorder and Observer software for a particular tag.

If any “NAME” text appears in the Excel file, it indicates that particular tag is not configured properly. Tag name may not available in Observer software. If this happens, check the valid tag names in Observer software at the following link

Real time viewer - Display – configuration data

Note: If Excel file is not opening from the selected path, then check the following

1. RAM size in the PC is very little. Restart the computer and then create the DDE link once again and open the Excel file.
2. Increase virtual memory in the PC. Please contact system administrator to check the virtual memory settings in the PC in following steps.
My computer-properties-advanced-performance settings –advanced-virtual memory.

DDE with third party applications

Once the data is available at Excel at particular cell, then data can be exchanged with the third party applications like PLC, SCADA, and Visual Basic etc.

If data is to be exchanged with PLC, then PLC programmer can write Visual basic macro in Excel from the following link

Excel – Tools – macro

For the source code examples, PLC programmer may check the PLC manuals for DDE sample macros.

It is also possible to exchange data from recorder to SCADA applications through DDE.

Example 1

DDE link between Allen-Bradley SLC 5/03 PLC and Excel

Task: Write a block of data (10 floating points) from Excel to PLC.

Name of the Excel file = Reports.XLS

Data Source: D 37 to D 46, data in total 10 cells

Target= PLC, Starting address= F8

User RSLinx to configure PLC and DDE link

DDE topic name in RSLinx= DDE_REPORTS

```
Sub Block_Write()
```

```
    'open dde link: testsol=DDE Topic This is comment only
```

```
    RSIch = DDEInitiate("RSLinx", "DDE_REPORTS")
```

```
    'write data thru channel This is comment only
```

```
    DDEPoke RSIch, "F8:2,L10", Range("[Reports.XLS]PROCESS!D37:D46")
```

```
    'close dde link This is comment only
```

```
    DDETerminate (RSIch)
```

```
End Sub
```

Example 2

DDE link between Allen-Bradley SLC 5/03 PLC and Excel

Task: Read a block of data (5 integers) from PLC to Excel

Name of the Excel file = Reports.XLS

Data Source: PLC, Starting address= N7:30

Target cells in Excel= A7 to A11

User RSLinx to configure PLC and DDE link

DDE topic name in RSLinx= DDE_REPORTS

```
Sub Block_Read()
```

```
    'open dde link: testsol=DDE Topic This is comment only
```

```
RSIchan = DDEInitiate("RSLinx", "DDE_REPORTS")
```

```
    'get data and store in data variable This is comment only
```

```
data = DDERequest(RSIchan, "N7:30,L5,C1")
```

```
    'Paste data into selected range This is comment only
```

```
Range("[Reports.XLS]DDE_Sheet!A7:A11").Value = data
```

```
    'close dde link This is comment only
```

```
DDETerminate (RSIchan)
```

```
End Sub
```

Example 3

DDE between Observer software and SCADA (Allen-Bradley RSVIEW32)

When the Real time viewer in Observer II is working well in PC, then the tag data from Observer software will be available in the expression format as follows

```
=RealTime_Viewer|TagService!_AI1
```

```
Application = RealTime_Viewer
```

```
Topic = TagService
```

```
Tag name = _AI1 (Please observe underscore before the name of the tag)
```

The above tag information can be directly configured in SCADA to enable DDE between Observer software and RSVIEW 32 SCADA. There is no need to configure any thing at RSLinx.

Procedure for configuration

- 1) Open SCADA project

- 2) System – Node – Select DDE server as data source
- 3) Name = VR18 (No gaps)
- 4) Application = RealTime_Viewer
- 5) Topic = TagService
- 6) Check enable in the box. (This node should be selected)
- 7) Now open the data base
- 8) Create analog tag with all the details similar to the tag at the recorder.
- 9) Select VR18 at the NODE
- 10) Write the tag address, this should be same as tag name at the recorder and Observer software.
For ex: analog input 1 AI1 should be written as _AI1 (Please note that underscore is required before the name of the tag, otherwise data will be not exchanged).
- 11) Now open the tag monitor and configure for the above tag for checking of DDE with the tag.

If DDE is configured properly, then tag value should appear correctly at the tag monitor with state as “VALID”. If any error message is available, then you have to repeat from step 1. Please note that before checking tag monitor, real time viewer in PC should be in running condition.

6. Application examples

Example 1: Flow measurement

A level has to be converted into a flow according to the following formula.

$$Q \text{ (calculated flow speed in liter per minute)} = 0.0072 * h \quad *60$$

$$h \text{ (level range in mbar per second)} = 0 - 30 \text{ mbar}$$

In **4.1 Channel** Mode of Configuration, set AI1 as follows,

Name: Level 1 Desc: xxxxxx
Method: Instant Speed: 1 S (1 second / data)
Offset: 0.00 Gain: 1.000
Sensor: Current Unit: mA Range: 4.0 20.0
Scale Unit: mbar Low: 0.00 High: 30.00

Press Math to get into Math Channel and set Math1 as follows,

Name: Flow 1 Desc: xxxxxx
Type: Enable Log Method: Instant Speed: 1 S
Expression: $0.0072 * AI1^{2.5} * 60$
Unit: l/min Low: 0.0 High: 2200.0

Example 2: 8:00 am start logging, 17:00 pm stop logging Monday-Friday

Select **Tools** mode of Configuration, and define Timer 1 – 4 as follows,

Timer 1		Timer 2	
Type: Daily	Action: Enable	Type: Daily	Action: Enable
Time: 8 Hour 0 Min.		Time: 17 Hour 0 Min.	
Job 1: Start logging		Job 1: Stop logging	
Timer 3		Timer 4	
Type: Weekly	Action: Enable	Type: Weekly	Action: Enable
Time: Saturday	8 Hour 1 Min	Time: Sunday	8 Hour 1 Min
Job1: Stop logging		Job1: Stop logging	

Example 3: Communicate recorder with mobile phone through SMS Mobile receiving process value and alarm messages from recorder via GSM8000

By using analog output card AO 183I and GSM controller GSM8000, it is able to retrieve process values and get alarms from the recorder to your Mobile via SMS through GSM system.

Hardware requirements

1. Paperless recorder VR18
2. Analog output card AO 183I
3. GSM 8000 controller (8 AI, 8 DI & 8 DO)

Set up at paperless recorder

Ex: RTD is connected at channel 1 in the recorder. (AI1)
Retransmission is required for Analog input1 say AI1

Use AO183I – Analog output card for Re transmission purpose. It is 3-channel analog output card.

Configuration of Analog output card

Channel 1:

1 | 2 | 3 |

Type: Current

Output: 4-20mA

Expression: AI1

Range: 0.0 ~ 100.0

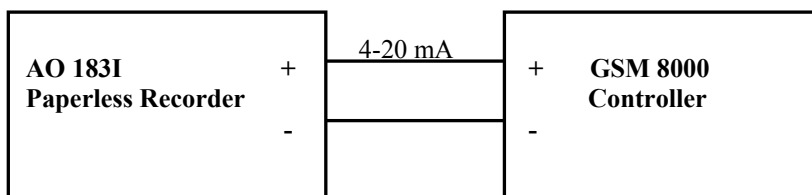

AO 183I: 3 channel analog output retransmission card

GSM 8000 controller: 8 Analog inputs, 4-20 mA

GSM 8000 controller set up

Insert SIM card in GSM controller, set up the controller as per user manual

Enter Supervisor and Operator mobile numbers in GSM controller. These are the mobile numbers to which SMS message to be sent from the GSM controller.

Select channel number1, set low scale for 4 mA = 0, set High scale for 20 mA = 100

Set Alarm levels, Low = 40 and High = 80

To know the process values in your Mobile

Send SMS from mobile to GSM controller as follows

GET-CH

This is to send SMS command from mobile to GSM controller to get analog inputs real time value. If the SMS command is properly framed and sent to GSM controller, then mobile will get the following confirmation from controller.

CHS = HHLHLLLL	Channel H/L/N status
	H = Reading on High value
	L = Reading on Low value
	N = Reading on Normal value
C1 = 60.2 oC	CH1 reading value with unit
C2 = 245.2 ACV	CH2 reading value with unit
C3 = 980.5 WATT	CH3 reading value with unit
C4 = 8.634 pH	CH4 reading value with unit
C5 = 200.5 uS	CH5 reading value with unit
C6 = 99.52 ACA	CH6 reading value with unit
C7 = 502.4 Lux	CH7 reading value with unit
C8 = 75.91 dB	CH8 reading value with unit

Alarm: Any time the alarm set on GSM controller been activated, SMS will be generated automatically from GSM controller, and sent to predefined the mobiles in similar format as above.

7. Trouble shooting

Trouble-shooting Flow Chart

Rev. A

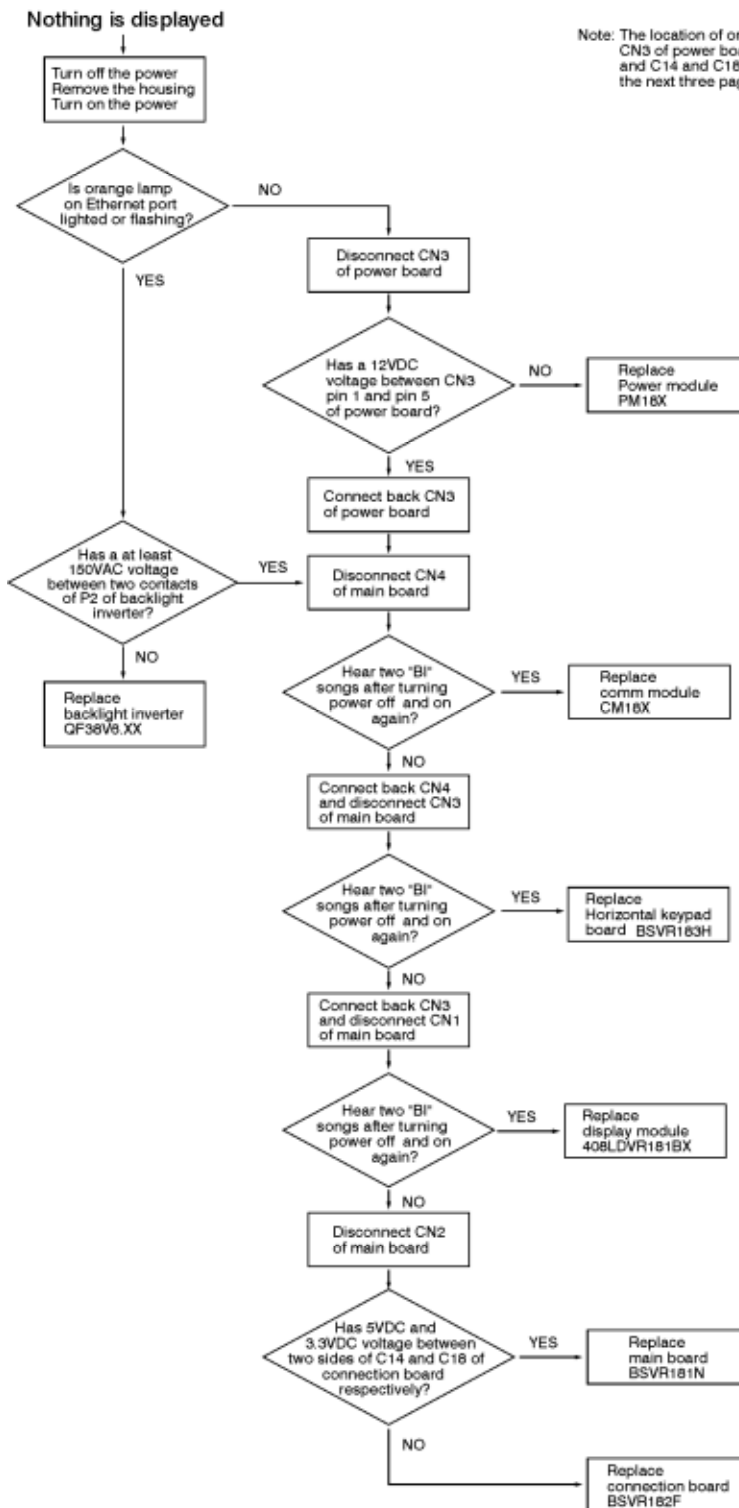

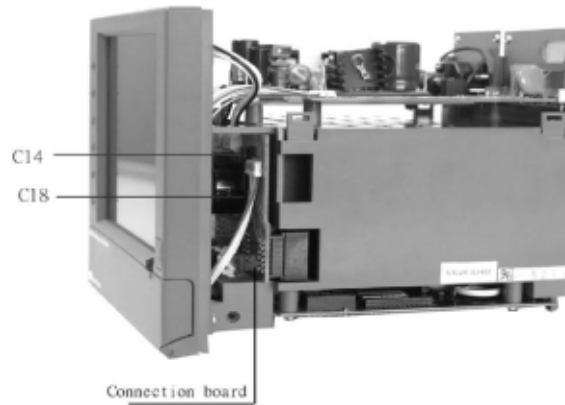
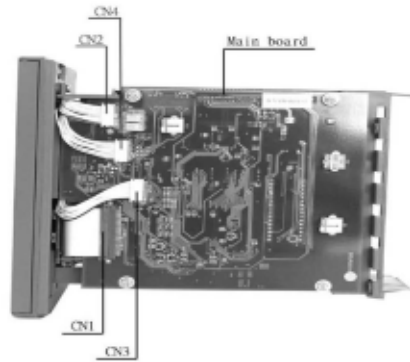
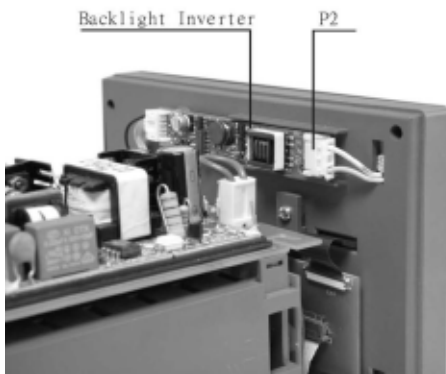
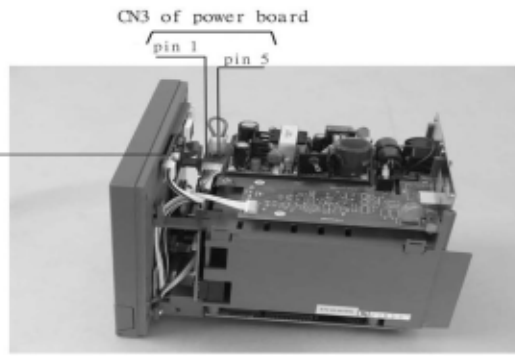
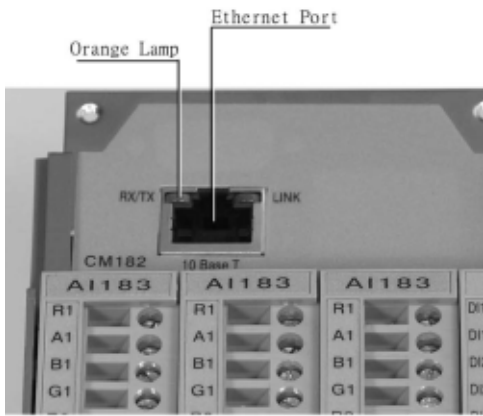

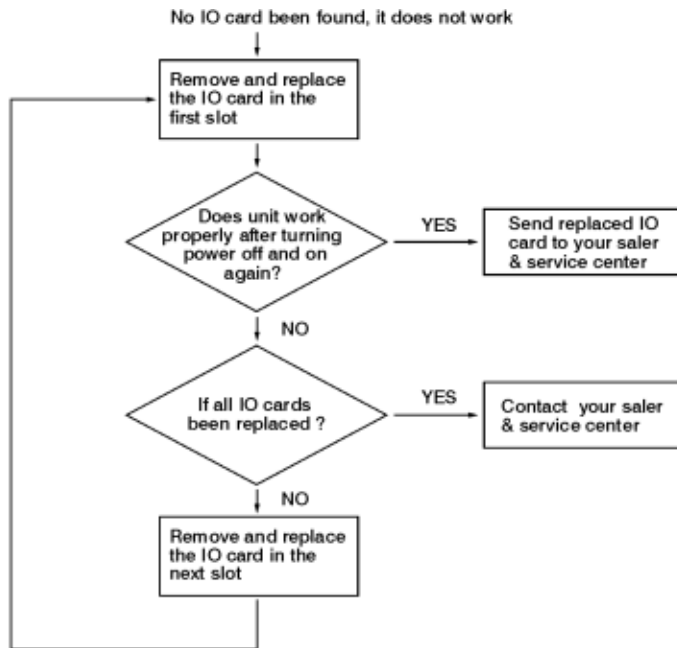

Note: (1) At least one of analog input card AI183X have to be installed if the unit is with core system firmware version V1.31 or earlier version.

(2) At least one of analog input card AI183X, digital input card DI181, digital output card DO181 or analog output card AO181 needs to be installed if the unit is with core system firmware version V2.0 or later version.

8. FAQs frequently asked questions

Q1: What is the maximum scale low and scale high values we can set in the recorder for the analog inputs and outputs?

A1: The minimum low scales of analog input are various -19999, - 1999.9, - 199.99, - 19.999, -1.9999, -0.19999 depending on the position of the decimal point

The maximum high scales of analog input are various 45536, 4553.6, 455.36, 45.536, 4.5536, 0.45536 depending on the position of the decimal point

The minimum low scales of Math input are various -32768, -3276.8, -327.68, -32.768, -3.2768, -0.32768 depending on the position of the decimal point

The maximum high scales of Math input are various 32767, 3276.7, 327.67, 32.767, 3.2767, 0.32767 depending on the position of the decimal point

Q2: What is the maximum distance between PC and Recorder for Ethernet communication?

A2: The distance is limited in 100 meters. If it is farther than that, then you can use Hub or networking bridge to strengthen the signal.

Q3: What is the maximum distance if PC is accessing data from recorder on wireless network through Ethernet protocol?

A3: Maximum distance should be within 30 meters. Also make sure that there is no obstacles/ HT cables between PC and recorder to avoid communication errors. Also Noise could effect the wireless communication at the factory floor.

Q4: Is there any battery available inside the recorder, which needs to be changed frequently?

A4: The lithium battery Toshiba CR2032 3.0V/220mAH can last for many years. It can be replaced by local sourcing if Real Time Clock is not working properly.

Q5: What is the accuracy of Real Time Clock in the recorder?

A5: The crystal oscillator used in recorder could have a lag time in a few seconds each week. Press Synchronization button in PC software Observer II to synchronize the time between PC and the recorder. The temperature inside the housing has an effect on accuracy of Real Time Clock of crystal oscillator.

Temperature range	Time lag per month
10 ~ 40 °C	18 sec.
0 or 50 °C	52 sec.
-10 or 60 °C	107 sec.

Q6: What kind of security is available in recorder?

A6: There are two kinds of security. The normal security offers a common password. The high security with FDA 21 CFR part 11 compliance is available from version 2.2 on both recorder and PC software Observer. It supports maximum 30 users with different passwords. The administrator has the right to define supervisor and operators. The supervisor can change configuration, save and clear data but not operators. Operators can only view the historical data, events and status.

Q7: What is Boot Rom? Anything related to Math option? Is it possible to upgrade it into new version via internet or CF card?

A7: Boot ROM is a chip available in recorder, which contains boot loader information. The Boot ROM BT181 has no option. The Boot ROM BT182 has options of Math, Counter, Totalizer & FDA 21 CFR part 11 compliance. It is required to remove BT181 away and install BT182 on the socket when those options are needed. It is not possible to upgrade it into new version via internet or CF card.

Q8: How does it upgrade into the new version of recorder system and PC software?

A8: If necessary, contact your supplier about the latest updates. The supplier is able to supply the latest version of recorder system and PC software via email or FTP (file transfer protocol) for easy download through internet. Follow the procedure to update it into the new version of recorder system. Install the new version of Observer software. It shall automatically uninstall the old one.

Q9: If it needs to upgrade the recorder system, what do we have to take care?

A9: Any recorder system before V 1.20, it is mandatory to update first to V 1.20 and then to the latest version i.e. it needs to upgrade twice. Direct update to the latest version could damage the DOC.

Q10: What are the differences between Observer I & Observer II PC software?

A10: Observer I is supplied for free. Observer II is supplied at additional cost. Observer I is used for recorder configuration from PC and also it is used for reading historical data in PC at set time period of 1 to 24 hours. Observer II is used for real time data monitoring in PC along with configuration and historical data view.

Q11: How many AI, AO, DI, DO cards, and 24VDC auxiliary power card can be inserted into the recorder?

A11: Maximum 6 cards in any combination can be inserted into rear Slots.

Q12: What are those larger capacities of compact flash cards supported by the recorder and recommended manufacturer?

A12: If the user prefers using larger capacities CF card we usually recommend 256MB or 1GB. To be fully compatible, we only recommend one brand **SanDisk** CF card.

Q13: What is the product warranty period of time? How does the user handle the defective recorder?

A13: It is 18 months after shipping from Taiwan. Contact your supplier once it becomes defective.

Q14: How does the agent handle the defective recorder? What is the leadtime for the repairs?

A14: To be cost effective, the agent is requested to verify and return the defective board according to the trouble shooting flow chart in the user manual. If it is difficult to verify the defective board, then the whole unit may be returned to the factory for repairing. The repairing is at no charge if it is within warranty period of time. It will be charged at reasonable cost, if it out of warranty. The lead-time will be 3 weeks after receiving the defective items by the factory.

Q15: What is the procedure to transfer data from the internal memory to CF card after the internal memory is full?

A15: After 8MB internal memory is full, the earliest data and events will be saved into CF card in small batch automatically, details in **3.11 Small icons**.

Q16: Is Alarm banner available in the recorder along with customized message display?

A16: Alarm banner is unavailable for customized message display. The alarm banner appears after alarms or events occurred, or the internal memory or CF card is running shortage. A buzzer can be set to activate if any alarms/events arise.

Q17: How many analog and math channels available and is it possible to retransmit these channels?

A17: Maximum 18 analog inputs plus 18 math inputs are available in one recorder. It is possible to retransmit the analog and math channels by using 3-channel current output card AO183I or 3-channel voltage output card AO183V..

Q18: Is the recorder supplied with OPC server?

A18: The OPC server is not available with the present recorder but the next generation. However Observer II PC software does offer DDE solution to allow data transferred to other devices like PLC, SCADA etc. Please review a few examples in **5.5 DDE dynamic data exchange**.

Q19: Which protocols and hardware interface recorder supports?

A19: For RS-232, RS-422, RS-485 communication, the protocol is Modbus RTU. For Ethernet communication, the protocol is TCP/IP.

Q20: How many recorders can be connected in a network?

A20: It depends on hardware interface selected. If it is Ethernet communication, maximum, 255 devices can be connected in the network, each device in unique IP address. If it is RS 485 communication, 247 units can be connected in the network then.

Q21: How many recorders can be viewed in the Real-time Viewer of PC software Observer II?

A21: Maximum 1024 tags can be viewed from the Real-time Viewer. These tags cover AI, Math, DI, DO, Counter and Totalizer, excluding AO. If each recorder is used with 6 tags in average, then the Real-time Viewer can view maximum 170 units of recorders.

Q22: Once the user forgot the password, is there a common password? If not, how to reset recorder to the factory settings?

A22: There is no common password for this purpose. It needs to do RESET procedure to recall the factory settings. Press and hold the top left key before turn on the power. Do not release it until you hear two "BI " sounds. Turn the power off and on again. All factory settings will be restored. Please note that, after this procedure, all project configuration data will erase. You have to configure the recorder like the beginning once again.

Q23: To change the analog input, what is the next step after changing the dip switches and jumpers on the analog input card?

A23: It needs to press the icon of Observer software to receive configuration about modified input from the recorder to PC first. Modify the configuration if necessary, and then send the new configuration back to the recorder.

Q24: Which type of Ethernet cable should be used to connect with the recorder?

A24: Straight through cable should be used for the real network connection between HUB and recorder. A cross through cable should be used for the non-real network connection, only between PC and recorder.

Q25: How many days the data can be stored in CF card?

A25: It depends on the number of channels, the log speed of channels, and the memory of CF card. If the recorder is used with **6-channel inputs**, an easy chart to show the maximum days CF can store the data.

CF card	128MB	512MB	1GB
Log speed			
1 second	120 days	480 days	960 days
10 seconds	1200 days	4800 days	9600 days
120 seconds	14400 days	57600 days	115200 days

Q26: Is it possible to display all the selected channels in one page on recorder?

A26: Yes, press **Page** key to get to **Page all** mode. Then, all selected channels in digits can be displayed in one page.

Q27: Is it possible to print out the data in selected time from the recorder?

A27: Please note that it is not possible to connect printer directly to the recorder. It is possible to print out the data in selected time from the Observer software. The printing data in Excel is available from the Historical Viewer of Observer software.

If any error appears like floating point error when user attempts to print data out, then the reason might be that data is not available for selected pens. Search it by a specific time or by a period of time, make sure that data is shown on the trend. Select the pen correctly, and then proceed the printing.

Q28: How many timers, counters and totalizers are available in a recorder?

A28: 6 counters, 6 timers and 18 totalizers are available in one recorder if this option been ordered.

Q29: Can I use digital inputs for the counting application?

A29: The recorder can detect maximum of 30 pulses/Minute at a frequency of 0.5 Hz. The possible alternative is usage of pulse to current 4-20 mA converter available in the market.

Q30: When the user is trying to open Observer software, he might get the following message, what is the next move?



A30: If Observer software file was corrupted in the PC, possible reasons might be virus, installation of new software which is incompatible with your operating system. The solution is to uninstall the old Observer software as per procedure given in section 1.4 of this software guide. Then, install the new Observer software from CD supplied. If the problem still can't be solved, then uninstall the old Observer software and create a back up for the historical and real-time folders under C:/Observer and remove Observer folder from C: Then install the new Observer software again.

Q31: How to write Observer data and configurations back up to CD's?

A31: Data will be available at .dat,idx files and .lst files at the path C:/Observer. The files will be available under historical and realtime folders. Configuration file name is Recorder.config. You can create a folder and save all historical and real time folders in to back up folder, and then you can write this information to CD.

Q32: If I have some configuration problems, which files I have that to send to the supplier?

A32: Both Recorder.cfg. and IO.dat. files in C:/Observer/Historical are required under this case.

Q33: Does the recorder have an option to supply DC power supply to the transmitters?

A33: The 24VDC auxiliary power supply card AP181 can offer the power to 6 pieces of transmitters.

Q34: I am trying to connect recorder on RS 232/RS422/RS485/Ethernet but I couldn't set up the communication properly.

A34: Please refer detailed information to **5.1 Observer I & Observer II PC software guide, 5.2 Ethernet Configuration & 5.3 RS 232, RS485, RS422 Configuration.**

Q35: When export data to Excel CSV files, what if the historical data is not appearing in spread sheet?

A35: Make sure that the selected pens are available at destination list. If they are available at source list, then move them to destination list, and then you can export data. Also make sure that data is available at the selected period or interval time. Otherwise, you may not see anything in the target Excel sheet.

Q36: I want to count pulses to measure power consumption in KWH. Each pulse is one KWH. Can I use Math application for this?

A36: Yes, use DI and configure Events of Channel as follows

Event Type = High, Job 1 = Increase Counter, Target = Counter 1

But please note that maximum value counter can store is 65535.

Please note that recorder can detect maximum of 30 pulses/Minute at a frequency of 0.5 Hz. The better possible solution is to use an external converter for the application. The standard pulses to 4-20mA converters are available in the market where you can set pulse width and duration between pulses.

Q37: I am getting the following message in Real time viewer. What to do next?



A37: The firmware V2.21 or earlier version does not allow the user to key in special characters like “.” “;” “*” “+” “-” etc. in Tag name. The user may change the tag name, or update the recorder firmware and PC software to V2.31 to avoid error message above.

Q38: I updated Observer software and recorder firmware to V 2.22 or above, DDE is not working properly with application of the third party.

A38: From Observer 2.22 on, DDE format has been changed with the Tag name. For example, instead of Analog input1 AIn, now it becomes TAGn, which n stands for the number of channel.

Q39: I want to exchange available data from Real-time Viewer with third-party applications in other computers in the same local area network, is there any solution?

A39: Real time viewer supports DDE application. It is possible to configure NetDDE and then exchange data from Real-time Viewer to other computers connected in the network via DDE. Please refer section 4.4.1.4 NetDDE for configuration details.

Q40: A customer complains that the clock of recorder is faster in 2 minutes each month. What is solution?

A40: Because of the nature of crystal, the real time clock of recorder might get a big error if the ambient temperature of recorder is high. The user should use the synchronization feature of PC software to synchronize the time of recorder with the time of PC. In configuration of PC software, click “Clock” icon, and click the “Synchronize” button, then it is done.

Written by: Henry Lin

BrainChild

Brainchild Electronic Co., Ltd.

No. 209, Chung Yang Road, Nan Kang Dist., Taipei, Taiwan, R. O. C.

Tel: 886-2-27861299 Fax: 886-2-27861395 E-mail: sales@brainchild.com.tw

Website: <http://www.brainchild.com.tw>